

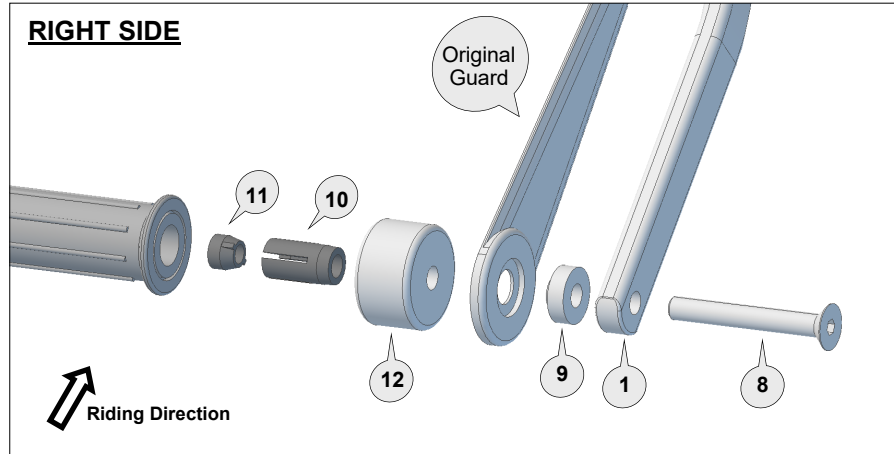

www.barkbusters.net

## FITTING INSTRUCTIONS for...

- DUCATI Multistrada 950/950S (2019 on)
  - DUCATI Multistrada 1200 (2015 on)
  - DUCATI Multistrada 1200 ENDURO (2016 on)
  - DUCATI Multistrada 1260/1260S (2018 on)
  - DUCATI Multistrada 1260 ENDURO (2020 on)
- (mounted in conjunction with original DUCATI plastic handguard)



### Preparation:

- Loosen Original Ducati handguard bolt from end of handlebar, approximately 2 turns.
- Remove black bar end with internal components from handlebar then disassemble from Original plastic handguard.

### Note:

Barkbusters Handguard and Lever Protector is to be mounted in conjunction with original Ducati plastic handguards. When mounted correctly, take care not to obscure indicators.

### FITTING TIP - 950 / 950S

Steering stops may need to be adjusted for improved clearance to windscreen support at full lock. May also need to reposition handlebar and controls up or down slightly.

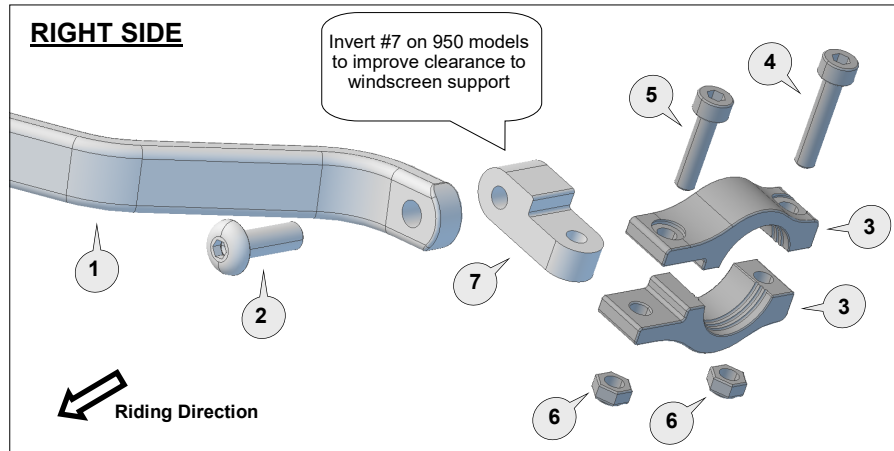

### Important Fitting Procedure

**Installation is shown for the right side.** Repeat for left side with applicable parts. Loosely fit the clamp parts to the tapered section of handlebar (see diagram).

**Note:** The rings machined on the inside of the clamp surface identify the larger section of the clamp. Rings must be positioned toward the larger section of the handlebar or centre of the motorbike.

**Important:** Rings on the top and bottom clamp halves, must align with each other.

- Attach bar end parts as per diagram to the backbone and original plastic handguard.
- Insert into handlebar end. Do not tighten at this stage.
- Attach inner end of backbone to clamp connector (7) with bolt (2).
- Tighten the bar end bolt (8) lightly.
- Position the backbone so it clears the tank by a minimum of 10mm when the steering is at full lock.

### \*\* WARNING \*\*

If you experience contact between the BARKBUSTERS and the windscreen support bracket at full lock, you will need to adjust the steering stop adjusters. It may only require half a turn of adjustment but may require more on some bikes. The steering stop adjuster position from the factory varies from bike to bike. Some bikes may not require adjustment. Steering stop adjusters (left & right) are positioned on the rear of the lower steering triple clamp.

Tighten all bolts in the following order using recommended torque specifications over page.

**Tighten bolt (8)** into the handlebar end.

**Tighten bolt (2)** through the aluminium bar (1) to the clamp connector (7) of the clamp assembly.

**Tighten bolt (5)** to solidly lock the clamp connector (7) between the clamp saddles (3).

**Tighten bolt (4)** to secure the clamp assembly firmly to the handlebar.

**Note:** The clamp is designed to allow the nut on bolt (5) to pull into the recessed hole. This eliminates the need for a wrench after the bolt starts to tighten.



Email: info@barkbusters.net

**1** Aluminium Bar (Black)



PN: BAR-LG-016

Pcs. 1 Left & 1 Right

**2** Button Head Bolt 25mm



PN: M8x25BHCSZP

Pcs. 2

**3** Clamp Saddles

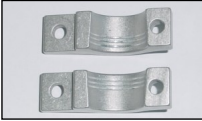

PN: CS-03

Pcs. 2 pairs

**4** Socket Head Bolt 30mm



PN: M6x30SHCSZP

Pcs. 2

**5** Socket Head Bolt 25mm



PN: M6x25SHCSZP

Pcs. 2

**6** Nylock Nut 6mm



PN: M6LN

Pcs. 4

**7** Clamp Connector



PN: CP6-V4

Pcs. 2

**8** Flat Head Bolt 70mm



PN: M8x70FHCSZP

Pcs. 2

**9** Spacer STEPPED



PN: SP8-19-8-S

Pcs. 2

**10** Expander



PN: BBE14A

Pcs. 2

**11** Taper Nut



PN: NUT 12

Pcs. 2

**12** Bar End Spacer



PN: BE-MTS16

Pcs. 2

**CAUTION:**

Installation of the handguard is safety-relevant work and can be complicated. We recommend the installation be performed by a motorcycle service technician. Rideworx accepts no liability for damages caused by improper mounting. All screws, bolts and nuts, including all replacement hardware provided by Rideworx, should be tightened to the torque specified in the table. After the first 50km of riding check all screws, bolts and nuts are tightened to the correct torque. We recommend a medium strength liquid thread lock product on all fasteners.

Recommended Torque Settings	
M6	10 Nm (7.4 lbf ft)
M8	23 Nm (17 lbf ft)

**WARNING:**

Check operation of all handlebar controls, specifically the throttle, front brake, kill switch and clutch to ensure they are operating correctly and are in accordance with the OEM specifications. Do not ride the motorcycle if any controls are not operating correctly. Check periodically that all bolts are tight.



Email: [info@barkbusters.net](mailto:info@barkbusters.net)  
 Web: [www.barkbusters.net](http://www.barkbusters.net)



**Disclaimer:**

A failure to follow these fitting instructions could cause serious injury, death or property damage. These handguards are intended solely for use with motorcycles/ATV/snowmobiles/scooters that have not been modified. They are not designed to prevent injury or death while riding or in an accident or crash. The user must ensure that all controls are free of the handguards every time that they ride. By installing and/or using this product you acknowledge that you accept these terms and have followed the fitting instructions.