



FITTING INSTRUCTIONS FOR LP0324BK LICENCE PLATE BRACKET
DUCATI HYPERMOTARD 950 2021-



THIS KIT CONTAINS THE ITEMS PICTURED AND LABELLED BELOW.
DO NOT PROCEED UNTIL YOU ARE SURE ALL PARTS ARE PRESENT.

Please note that the way the kit is packed does not necessarily represent the way of mounting to the bike.

THE PARTS SHOWN MAY BE REPRESENTATIVE ONLY (FOR CLARITY OF INSTRUCTIONS ONLY).

Please note that in cases where kits are packed with rubber washers holding the components onto the bolt – *the rubber washers should be thrown away!*

Digital copies of these instructions are available to download from www.rg-racing.com

TOOLS REQUIRED

- Set of metric Allen keys to include 4 & 6mm
 - Socket set to include 6mm & 8mm
 - T20 Torx tool
 - 12mm A/F Spanner
 - Small flat bladed screwdriver
 - Small amount of adhesive
 - Loctite or similar

MAXIMUM TORQUE SETTINGS

- M4 BOLT = 8Nm
- M5 BOLT = 12Nm
- M6 BOLT = 15Nm
- M8 BOLT = 20Nm
- M10 BOLT = 40Nm

R&G

Unit 1, Shelley's Lane, East Worldham, Alton, Hampshire, GU34 3AQ
 Tel: +44 (0)1420 89007 Fax: +44 (0)1420 87301 www.rg-racing.com Email: info@rg-racing.com

**LEGEND**

- Item 1 = TB0323 PART 1 - LICENCE PLATE BRACKET
- Item 2 = TB0274 PART 2 - HEAT SHIELD (SINGLE SIDED)
- Item 3 = I0033 MINI INDICATOR ADAPTOR (4)
- Item 4 = S1189 SS HEAT SHIELD SPACERS (4)
- Item 5 = S1190 MINI INDICATOR SPACER (2)
- Item 6 = S0253 6MM EXHAUST SPACERS (2)
- Item 7 = M5x30mm COUNTERSUNK BOLTS (4)
- Item 8 = M5 LOCKING NUTS (4)
- Item 9 = 2.5mm CABLE TIES x 100mm LONG (8)
- Item 10 = LA0002 No PLATE LIGHT ASSEMBLY (INCLUDES SHROUD)
- Item 11 = CON15 MINI INDICATOR ADAPTORS (2)
- Item 12 = CON14 TAIL-LIGHT CONNECTOR
- Item 13 = 200mm LENGTH OF HEAT-SHRINK (3)
- Item 14 = MINI INDICATOR WIRING COVERS (2)
- Item 15 = SELF-ADHESIVE CABLE CLIPS (4)
- Item 16 = REFLECTOR

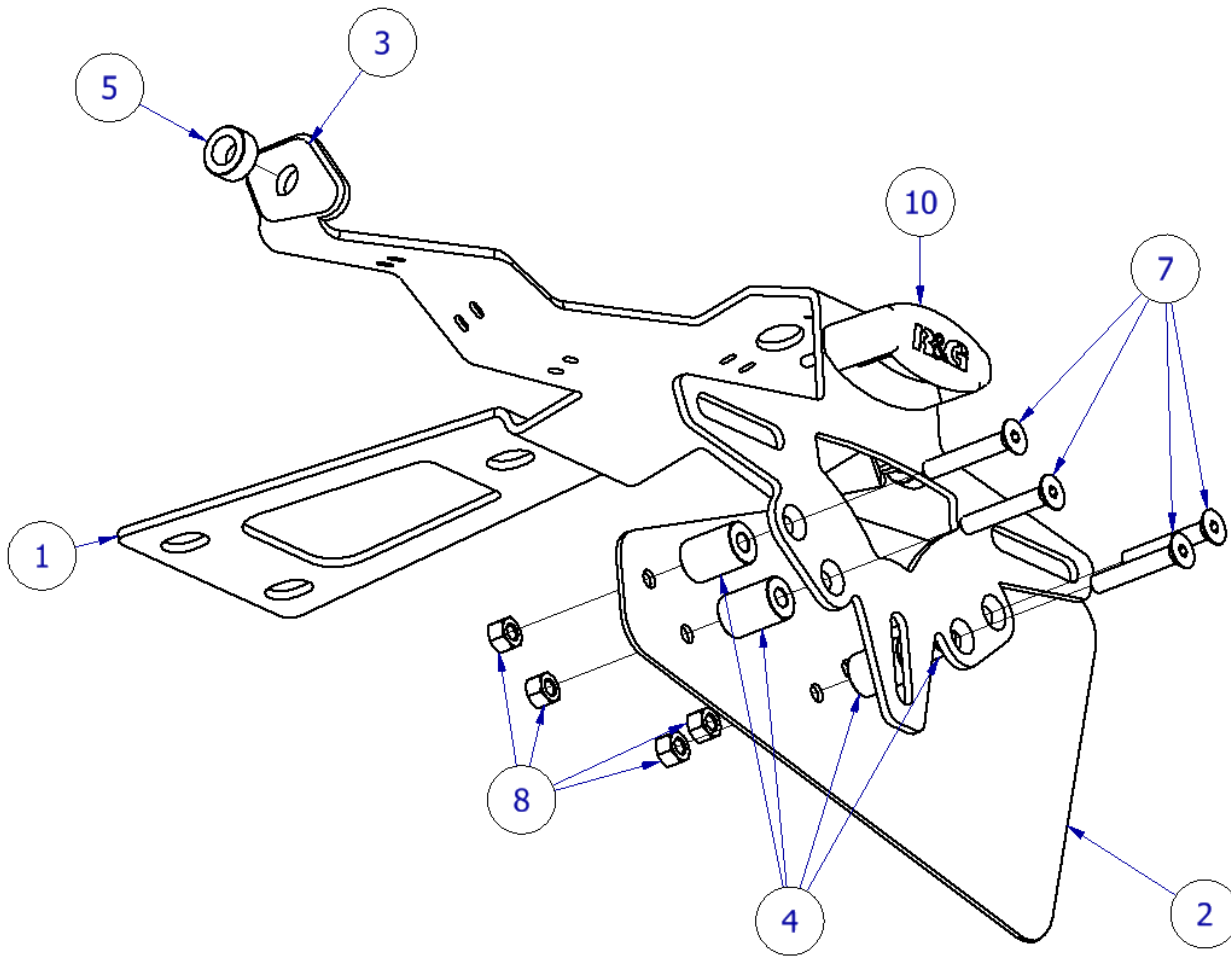
**ASSEMBLY DIAGRAM 1**

R&G

Unit 1, Shelley's Lane, East Worldham, Alton, Hampshire, GU34 3AQ

Tel: +44 (0)1420 89007 Fax: +44 (0)1420 87301 www.rg-racing.com Email: info@rg-racing.com

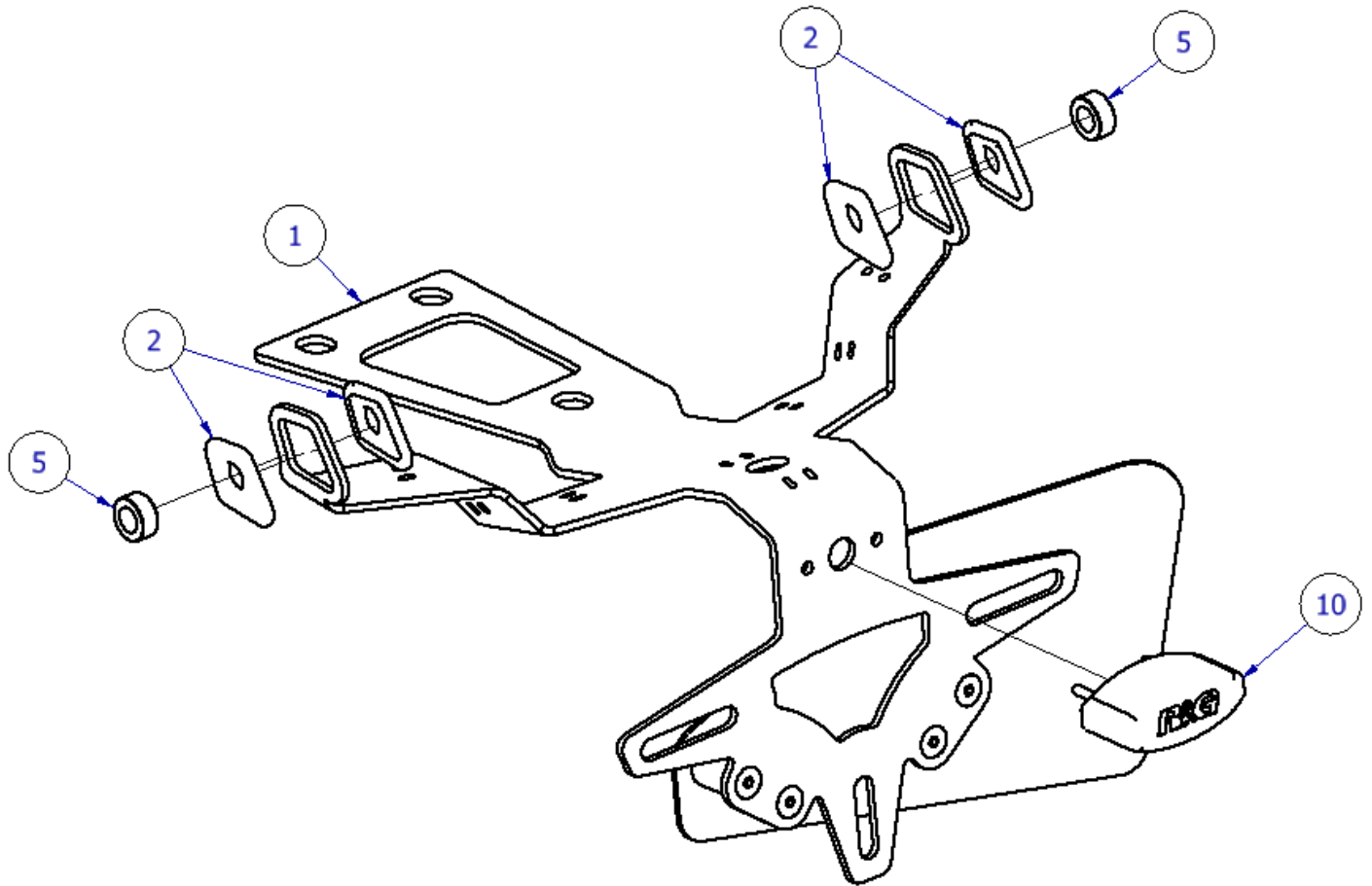

ASSEMBLY DIAGRAM 2

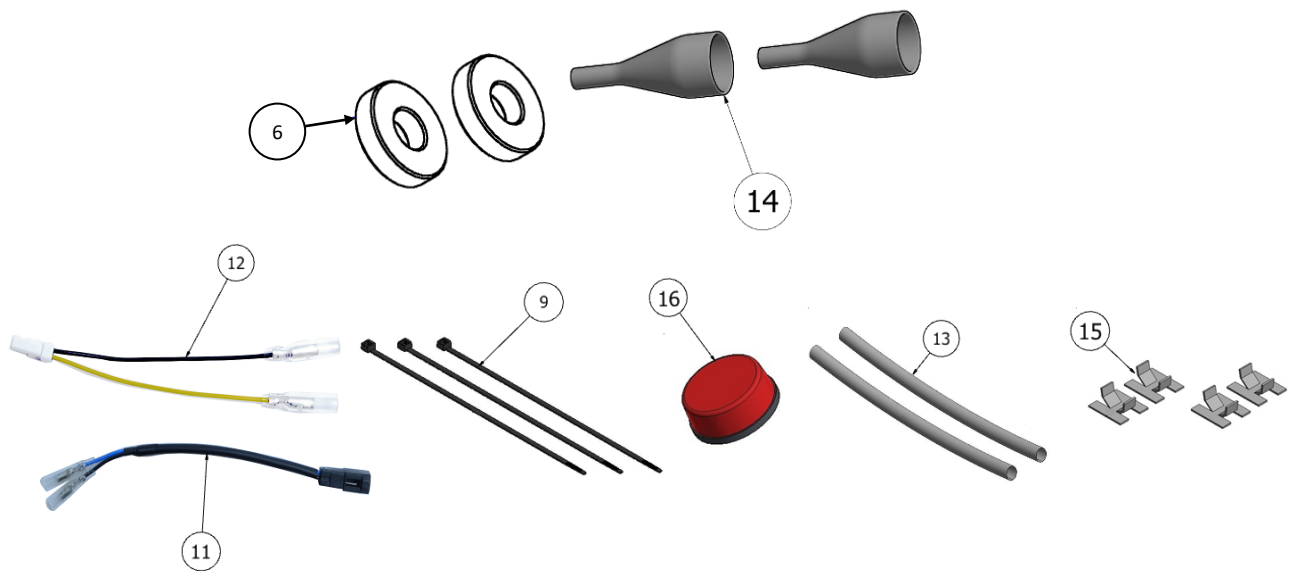

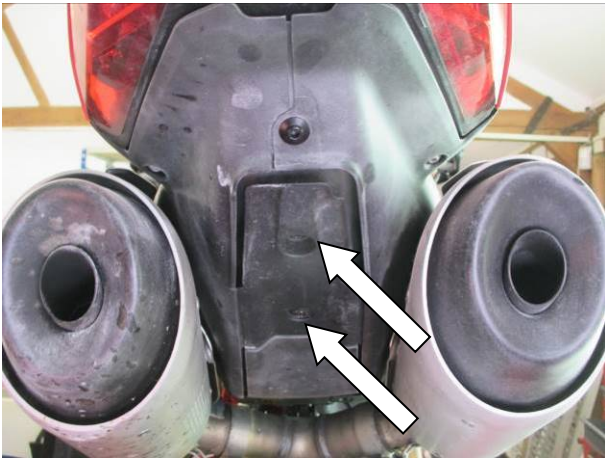

Picture 1

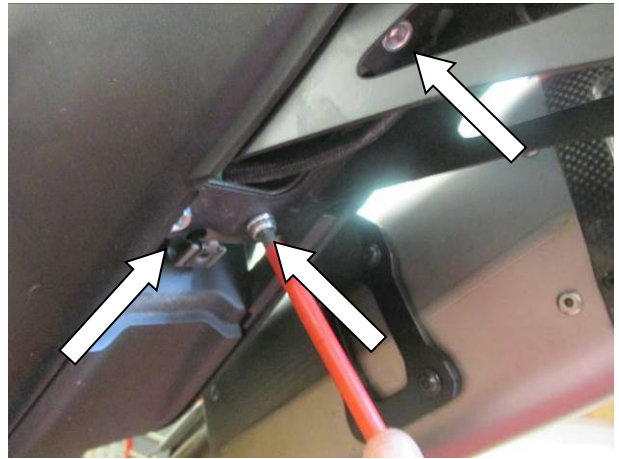

Picture 2



Picture 3

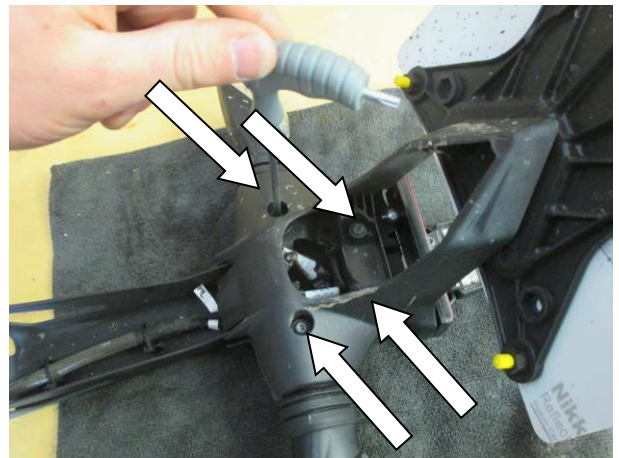

Picture 4



Picture 5

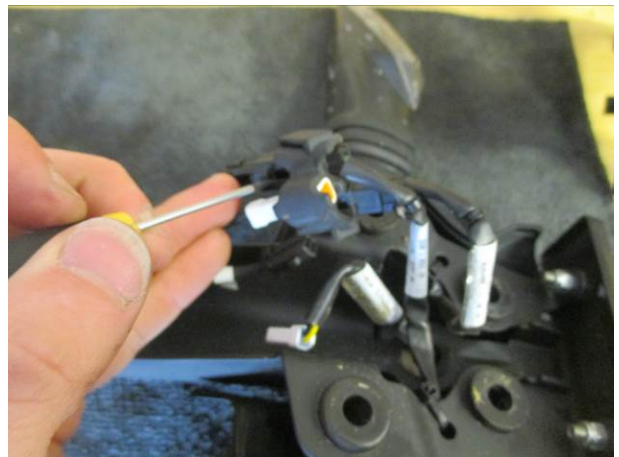

Picture 6



Picture 7

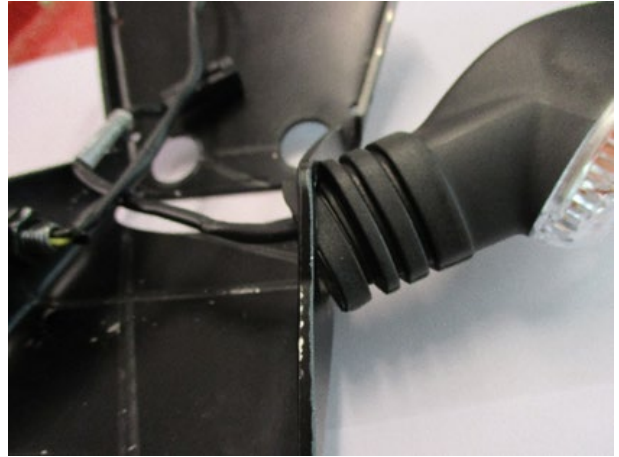

Picture 8

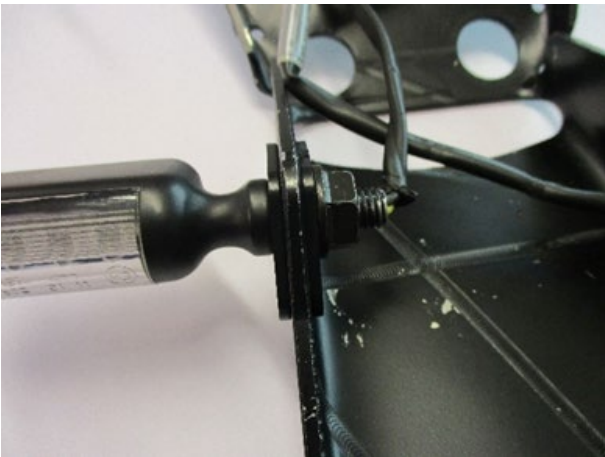

Picture 9

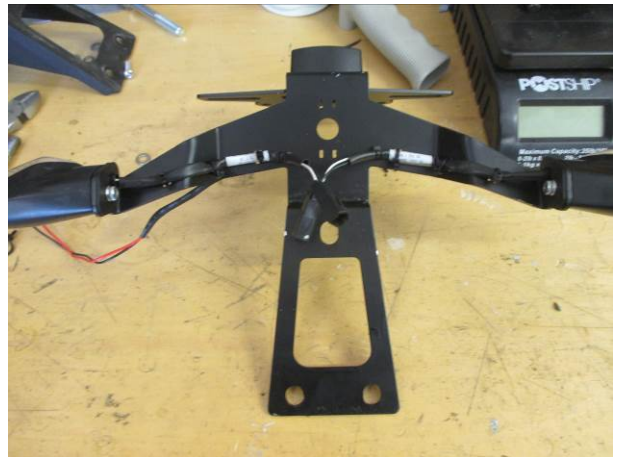

Picture 10

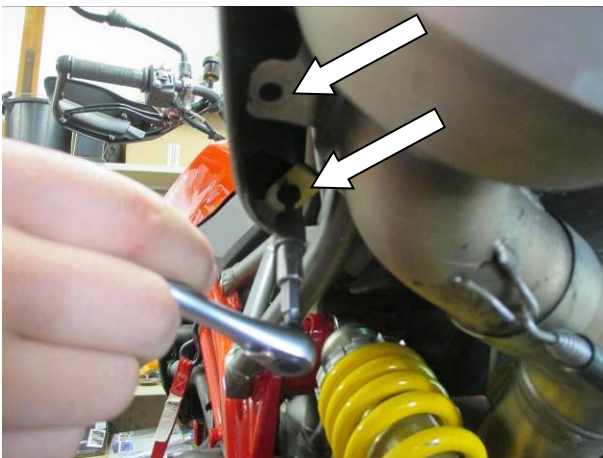

Picture 11



Picture 12

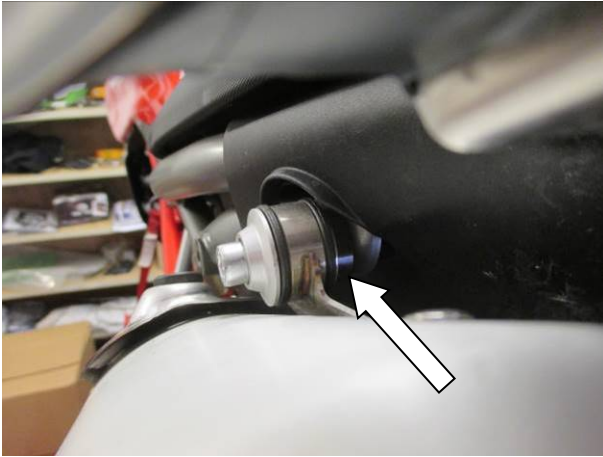

Picture 13



Picture 14



Picture 15



Picture 16



FITTING INSTRUCTIONS

OEM Tail Unit Removal:

- Begin by removing the panel under the tail unit by removing the two bolts arrowed in **picture 1** using a 4mm allen key.
- Carefully remove the 3 allen head bolts holding the OEM licence plate holder to the bike shown in **picture 2** using a 6mm allen key, ensuring to support the unit when removing these bolts to prevent the unit dropping.
- As you remove the licence plate holder from the tail unit, you will need to disconnect the wiring as shown in **picture 3** using a small flat bladed screwdriver, the licence plate holder should now be free from the bike.
- On the underside of the OEM licence plate holder, remove the 4 torx screws shown in **picture 4** and split the indicator housing by removing the lower plastic piece and sliding the upper piece off the rubber mounts in the metal tail piece shown in **Picture 5**, leaving the indicators loose.
- Remove the rubber indicator connector holder and disconnect the 3 connectors using a small flat bladed screwdriver as in **Picture 6** and remove both indicators completely.
- Disconnect the OEM licence plate light as before and cut the cable ties that secure the tail piece wiring loom to the metal bracket and remove from the bike as shown in **picture 7**. Put this to one side for use later.

R&G Tail Tidy Assembly:

- To assemble the tail tidy, the heat shield (item 2) should be attached to the main tail bracket (item 1), referring to **Assembly diagram 1** on page 2.
- Place the 4 x 30mm countersunk bolts (item 7) into the corresponding holes on the main tail bracket (item 1) and slide one heat shield spacer (item 4) over each bolt.
- Locate the heat shield (item 2) over the exposed threads and sandwich the spacers using the 4 x locking nuts (item 8) to secure the heat shield. Ensure that the locking nuts are fully engaged with 1-2 threads protruding through the nuts.
- Next, take one length of provided heat shrink (item 13) and place this over the wires of the R&G number plate light (Item 10). Heat this with a heat gun or similar until the wires are neatly wrapped.
- The number plate light shroud provided with the assembly should be affixed to the light unit using a small amount of superglue to hold in place, this is to correctly direct the light downwards to prevent dazzling other road users.
- Affix this to the main tail tidy bracket as shown in **Assembly diagram 2** on page 3 using the M4 washers and nuts provided with the assembly. Tighten the nuts using a 6mm socket.
- Attach the CON14 tail light connector (item 12) to the bullet connectors of the licence plate illuminator.

If using OEM Indicators:

If you are re-using the OEM Ducati indicators these will need to be removed from the OEM licence plate unit following the steps here, if using Mini indicators, skip this section.

- Cut the cable ties securing the wiring and remove the indicator (please note which side it came off).
- Repeat the above to remove the other indicator (please note the relevant sides).

R&G

Unit 1, Shelley's Lane, East Worldham, Alton, Hampshire, GU34 3AQ

Tel: +44 (0)1420 89007 Fax: +44 (0)1420 87301 www.rg-racing.com Email: info@rg-racing.com



- Gently squeeze the indicator stem and push through the shape aperture in the new licence plate bracket (item 1) as shown in **picture 8** (a small amount of silicon grease or liquid detergent helps in this process)
- Fit the indicators to the new licence plate bracket (item 1) as they were mounted originally (ensure they are fitted on the correct sides).

If using R&G Mini Indicators:

- To fit the mini indicators, first use one piece of heat shrink (item 13) over each pair of wires and heat this with a heat gun or similar until the wires are neatly wrapped.
- Fit one Mini indicator spacer (item 5) over wire and thread of each mini indicator.
- Thread one indicator fastening plate (item 3) over each pair of indicator wires with the wires passing through the larger hole.
- Thread each indicator assembly through each indicator mount on the tail tidy bracket (part 1).
- To neaten the wiring, slide one indicator wiring cover (item 14) over the bullet connectors for each indicator and slide up until the flanged nut is covered. *A small amount of lubricant or soap may help when pushing the wires through the indicator wiring cover.*
- Use the two remaining indicator fastening plates (item 3) to sandwich the indicator on the main tail bracket as shown in **Assembly diagram 2** on page 3 and **picture 9**. It is recommended to use a small amount of Loctite when fastening the flanged indicator nut to help keep the assembly tight.
- After fastening both indicators, use cable ties (item 9) to secure the exposed wires to the top surface of the tail bracket as shown in **picture 10**.
- Fit one Mini CON15 indicator adaptor (item 11) to each mini indicator via bullet connectors to the corresponding wire colours.

Exhaust Spacer fitting:

In order to help with heat dissipation from the exhaust, you are provided with 2 x 6mm exhaust spacers (item 6) these MUST be fitted to the bike to eliminate the risk of damage to the licence plate or tail bracket.

- Remove the rear side panels from both sides of the bike by removing the two hex bolts arrowed in **picture 11**.
- Lift the panel away from the bike as in **picture 12** to reveal the exhaust bracket mounts.
- One side at a time, remove the allen head bolt securing the exhaust to the frame of the motorcycle and place the 6mm spacer between the exhaust and mount as arrowed in **picture 13**. You may need to swivel the exhaust cans to achieve this, ensuring the exhaust exit is directed further outwards from the centre than before.
- Replace the exhaust mounting bolt before repeating on the other side.
- At this stage, start the bike and check for any exhaust leaks and reposition as appropriate.
- Re-fit the tail unit side panels in their original position.

Fitting Tail Tidy to bike:

- With both indicators and licence plate illuminator attached to the tail tidy, you should now connect the OEM tail unit loom removed earlier to the indicator and licence plate light connectors, ensuring that the indicators are connected to the corresponding side.
- Route the licence plate illuminator wires from the underside up through the hole in the centre of the tail tidy.

R&G

Unit 1, Shelley's Lane, East Worldham, Alton, Hampshire, GU34 3AQ

Tel: +44 (0)1420 89007 Fax: +44 (0)1420 87301 www.rg-racing.com Email: info@rg-racing.com



- Neatly arrange the wires depending on your indicator choice using the self-adhesive cable clips (item 15) keeping as much of the wiring as possible on the top surface of the tail tidy as this will make them less visible when fixed to the bike.
- Before fitting the Tail Tidy, connect the tail tidy wiring loom to the motorcycle wiring loom as shown in **picture 14** and test all lights function correctly. If illumination fails, swap the bullet connectors around.
- With all lights working, offer the complete tail tidy assembly up to the rear of the bike and use the 3 x OEM cap head bolts removed earlier and loosely fix this in place as shown in **Picture 15**.
- Position the tail tidy as near to the rear of the bike as possible using the slotted mounting holes and tighten the 3 cap head bolts to the correct torque.
- Carefully wrap any extra wire and place through the tail tidy opening and into the open recess in the underside of the motorcycle tail unit.
- Re-fit the cover panel on the underside of the tail unit using the two bolts removed earlier, ensuring the wires pass through the gap in the RHS of the panel as shown in **picture 16**.
- Mount the licence plate (it may require drilling) to the rear of the bracket in a central position, ensuring that it does not overhang the edges of the heat shield.
- **IMPORTANT: IF FITTING A FULL-SIZE LICENCE PLATE AND PLACING IT FAR DOWN ON THE LICENCE PLATE HANGER, THERE IS A SMALL CHANCE OF THE LICENCE PLATE HITTING THE BACK WHEEL UNDER HEAVY LOAD AND OVER LARGE BUMPS IN THE ROAD. IT IS YOUR RESPONSIBILITY TO CHECK FOR THIS POSSIBILITY AND TAKE AVOIDING ACTION. FAILURE TO CHECK THIS COULD RESULT IN SERIOUS INJURY.**
- Depending on local laws, attach enclosed reflector (item 16) in an appropriate location.
- Retest the licence plate illuminator and all lights before riding.

ISSUE 1 06/08/21 (AO)

CONSUMER NOTICE

The catalogue description and any exhibition of samples are only broad indications of the Products and R&G may make design changes which do not diminish their performance or visual appeal and supplying them in such state shall conform to the order. The Buyer acknowledges no representation or warranty (other than as to title) has been given or will apply to the Products other than those in R&G's order or confirmation and the Buyer confirms it has chosen the Products as being of merchantable quality and suitable for its particular purposes. Where R&G fits the Products or undertakes other services it shall exercise reasonable skill and care and rectify any fault free of charge unless the workmanship has been disturbed. The Buyer is responsible for ensuring that the warranty on the motorcycle is not affected by the fitting of the Products. On return of any defective Products R&G shall at its option either supply a replacement or refund the purchase money but shall not be liable if the Products have been modified or used or maintained otherwise than in accordance with R&G's or manufacturer's instructions and good engineering practice or if the defect arises from accident or neglect. Other than identified above and subject to R&G not limiting its liability for causing death and personal injury, it shall not be liable for indirect or consequential loss and otherwise its liability shall be limited to the amounts paid by the Buyer for the Products or the fitting or service concerned. These terms do not affect the Buyer's statutory rights.

R&G RETURNS POLICY (NON-FAULTY GOODS)

Returns must be pre-authorized (if not pre-authorized the return will be rejected). Goods may only be returned direct to us if they were purchased direct from us (customer must prove if necessary). Otherwise to be returned to original vendor. Goods must be in re-sellable condition, in the opinion of R&G. All returns are subject to a 25% restocking and handling fee (25% of the gross value exc. P&P – at the prevailing price at time of purchase). The customer must pay any and all carriage charges. No returns of discontinued products, unless within 14 days of purchase. This policy does not affect your statutory rights and does not refer to faulty goods.

R&G

Unit 1, Shelley's Lane, East Worldham, Alton, Hampshire, GU34 3AQ

Tel: +44 (0)1420 89007 Fax: +44 (0)1420 87301 www.rg-racing.com Email: info@rg-racing.com