



FITTING INSTRUCTIONS FOR LP0340 LICENCE PLATE BRACKET



**This kit contains the items pictured and labelled over page.
Some parts may be shown for clarity of instructions only.
Do not proceed until you are sure all parts are present.
Please read all instructions before proceeding.**

**IF IN ANY DOUBT WHEN FITTING OUR PRODUCTS, CONSULT ONE OF OUR DEALERS
OR HAVE FITTED BY A QUALIFIED TECHNICIAN.**

Please note that the way the kit is packed does not necessarily represent the way of mounting to the bike.

In the event of rubber washers being used to hold components onto bolts, these rubber washers can be thrown away.

DIGITAL COPIES OF THESE INSTRUCTIONS ARE AVAILABLE FROM

WWW.RG-RACING.COM

R&G

Unit 1, Shelley's Lane, East Worldham, Alton, Hampshire, GU34 3AQ
Tel: +44 (0)1420 89007 Fax: +44 (0)1420 87301 www.rg-racing.com Email: info@rg-racing.com



<u>TOOLS REQUIRED</u>	<u>GENERAL TORQUE SETTINGS</u>
<ul style="list-style-type: none"> • Set of metric Allen keys. • Set of metric sockets and wrench. <ul style="list-style-type: none"> • 12mm spanner. • Phillips screwdriver. • Cable cutters 	<p>M4 BOLT = 8Nm</p> <p>M5 BOLT = 12Nm</p> <p>M6 BOLT = 15Nm</p> <p>M8 BOLT = 20Nm</p> <p>M10 BOLT = 40Nm</p> <p>M12 BOLT = 40Nm</p>

LEGEND

ITEM No.	DESCRIPTION	QTY
ITEM 1	LICENCE PLATE BRACKET	1
ITEM 2	MAIN SUPPORT BRACKET	1
ITEM 3	COVER PLATE	1
ITEM 4	M5 COUNTERSUNK BOLT	7
ITEM 5	M5 WASHERS	7
ITEM 6	LA0002 NUMBER PLATE LIGHT & SHROUD	1
ITEM 7	M5 NYLOC NUTS	7
ITEM 8	M6 BUTTON HEAD BOLT	4
ITEM 9	M6 WASHERS	4
ITEM 10	2.5MM CABLE TIES	4
ITEM 11	SELF ADHESIVE CABLE CLIP	2
ITEM 12	REFLECTOR	1
ITEM 13	150mm LENGTH OF HEAT SHRINK	1
ITEM 14	CON0014 WIRING ADAPTOR (SEE PICTURE 14 FOR ILLUSTRATION)	1

R&G

Unit 1, Shelley's Lane, East Worldham, Alton, Hampshire, GU34 3AQ

Tel: +44 (0)1420 89007 Fax: +44 (0)1420 87301 www.rg-racing.com Email: info@rg-racing.com



ASSEMBLY DIAGRAMS

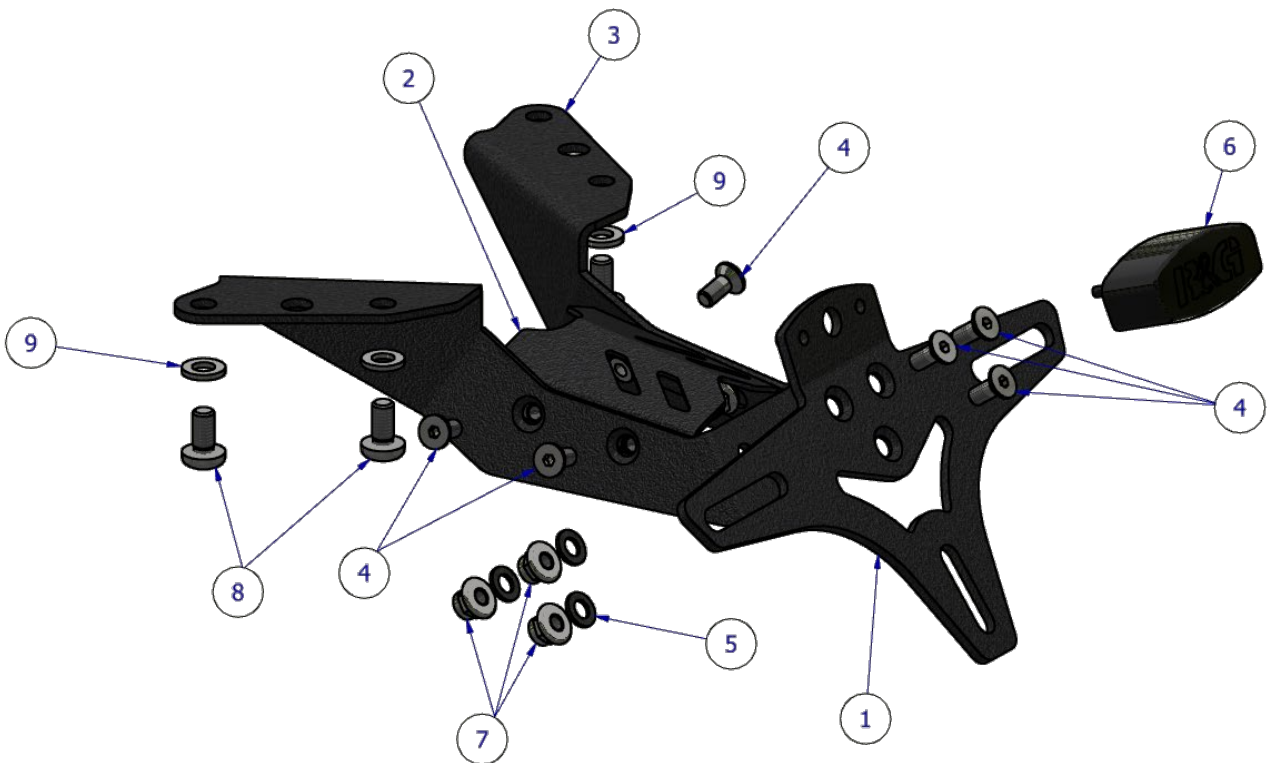
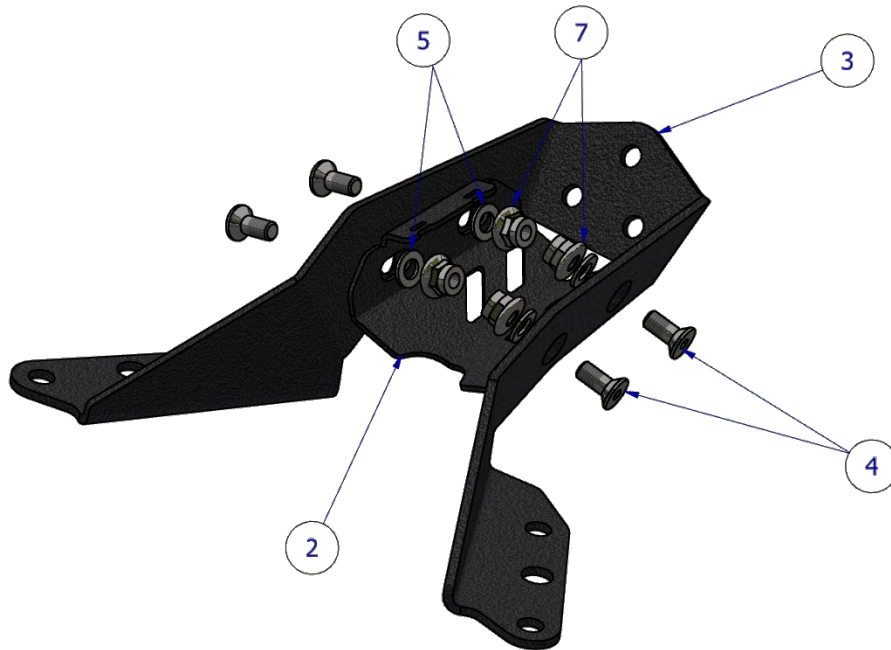

R&G

Unit 1, Shelley's Lane, East Worldham, Alton, Hampshire, GU34 3AQ

Tel: +44 (0)1420 89007 Fax: +44 (0)1420 87301 www.rg-racing.com Email: info@rg-racing.com

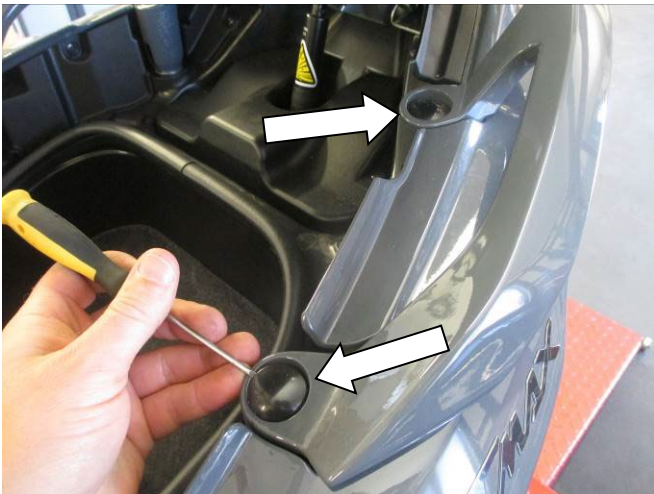
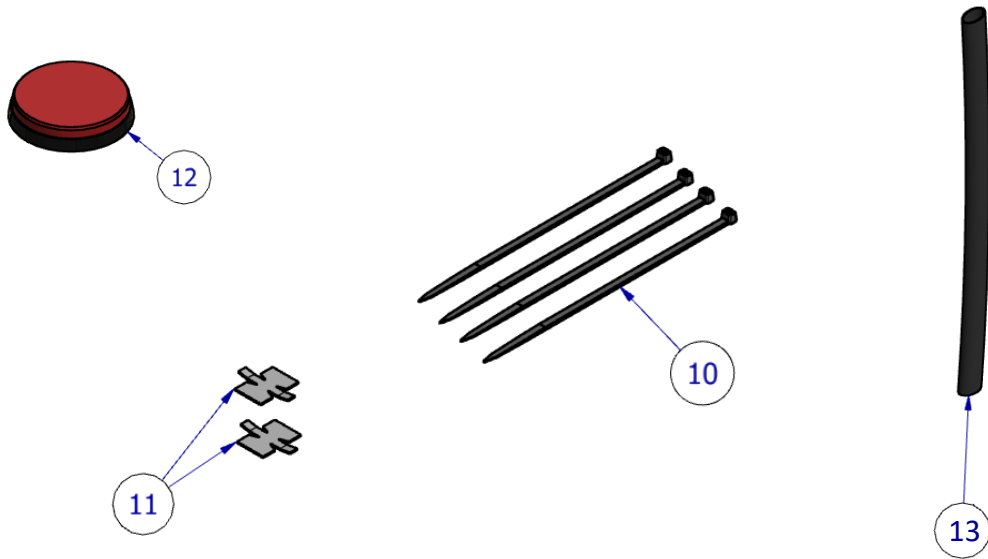

Picture 1



Picture 2



Picture 3



Picture 4



Picture 5



Picture 6



Picture 7



Picture 8

R&G



Picture 9



Picture 10



Picture 11

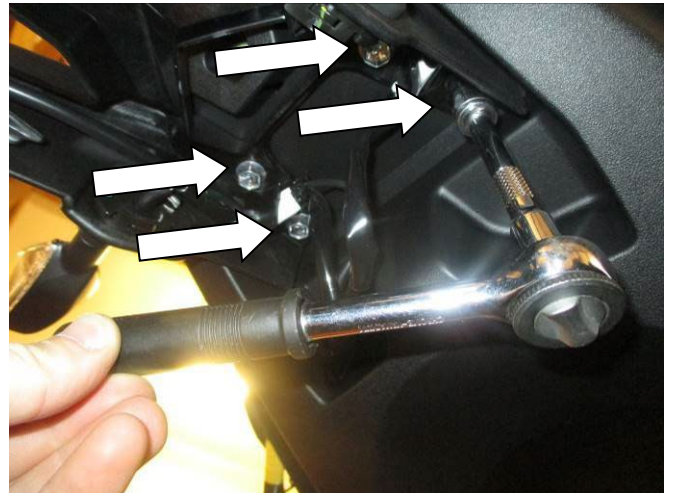

Picture 12



Picture 13

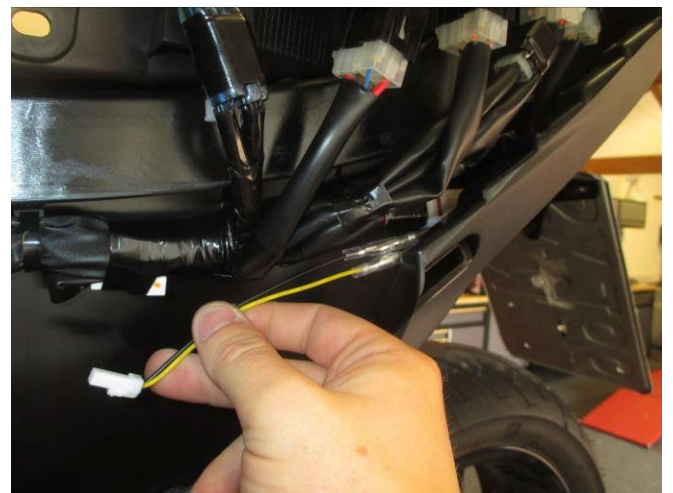

Picture 14



Picture 15

FITTING INSTRUCTIONS

- To fit the R&G tail tidy, lift the seat using the key and release button.
- Remove the two plastic covers on the handrail on the left side of the bike, as arrowed in picture 1, and remove the two bolts underneath. Remove the handrail from the bike.
- Remove the rubber panel adjoining the rear panels to gain access to the bolts underneath, as shown in picture 2.
- Unclip and remove the rubber cover shown in picture 3 and remove the bolt shown in picture 4.
- Remove the bolts shown in pictures 5-10. This will allow you to remove the side panel shown in picture 5, and allow access to the final bolt to remove in order to remove the larger side panel which will reveal the wiring for the OEM tail unit.
- Disconnect the connector shown in picture 11 and cut any cable ties securing the tail unit wiring to the bike.
- While supporting the tail unit Remove the 4 x hex bolts in the underside of the OEM tail unit as shown in picture 12.
- Remove the OEM tail unit from the bike ensuring to pass the wiring through the opening in the LHS of the bike and remove completely.
- Offer the cover plate (**Item 3**) up to the main bracket (**Item 2**) and secure in place using 4 of the M5 countersunk bolts (**Item 4**), M5 washers (**Item 5**) and M5 nyloc nuts (**Item 7**).
- Feed the wire of the new R&G licence plate illuminator (**Item 6**) through the upper central hole in the new licence plate bracket (**Item 1**) and underneath the cover plate (**Item 3**).
- Secure the illuminator using the M3 washers and nuts supplied as shown in picture 13.
- Fit one length of heat-shrink (**Item 13**) to the wires and heat gently to shrink to fit.
- Fit the light shroud and use a small amount of adhesive to hold it in position; this will help direct the light correctly.
- Neatly route the wiring with the licence plate illuminator wiring using the cable ties and cable clips supplied.
- Take the tail tidy assembly and offer it up underneath the tail whilst feeding the wire up through the small hole where the OEM wiring exited from, attach the CON0014 adaptor (**Item 14**) as shown in picture 14 and plug the CON0014 into the OEM harness.

R&G

Unit 1, Shelley's Lane, East Worldham, Alton, Hampshire, GU34 3AQ

Tel: +44 (0)1420 89007 Fax: +44 (0)1420 87301 www.rg-racing.com Email: info@rg-racing.com



- Take the four M6 x 16mm long button head bolts (**Item 8**) and four M6 washers (**Item 9**) and fit through the four mounting holes of the tail tidy before tightening into the threaded bosses on the subframe, as shown in picture 15.
- Check for the correct operation of all lights, if illumination fails on any light, re-connect the bullet connectors the other way around.
- Ensure the wiring is all neatly routed behind the panel using the cable ties (**Item 10**) and self-adhesive cable clips (**Item 11**).
- Re-fit the bodywork and the hand-rails in a reverse procedure of how they were removed.
- Re-fit the licence plate (it may require drilling).
- Depending on local laws, attach enclosed reflector (**Item 12**) in an appropriate location.
- Test the licence plate illuminator and all lights before riding.
- **IMPORTANT: IF FITTING A FULL-SIZE LICENCE PLATE AND PLACING IT FAR DOWN ON THE LICENCE PLATE HANGER, THERE IS A SMALL CHANCE OF THE LICENCE PLATE HITTING THE BACK WHEEL UNDER HEAVY LOAD AND OVER LARGE BUMPS IN THE ROAD. IT IS YOUR RESPONSIBILITY TO CHECK FOR THIS POSSIBILITY AND TAKE AVOIDING ACTION. FAILURE TO CHECK THIS COULD RESULT IN SERIOUS INJURY.**

ISSUE 1 26/10/2022 (MH)

CONSUMER NOTICE

The catalogue description and any exhibition of samples are only broad indications of the Products and R&G may make design changes which do not diminish their performance or visual appeal and supplying them in such state shall conform to the order. The Buyer acknowledges no representation or warranty (other than as to title) has been given or will apply to the Products other than those in R&G's order or confirmation and the Buyer confirms it has chosen the Products as being of merchantable quality and suitable for its particular purposes. Where R&G fits the Products or undertakes other services it shall exercise reasonable skill and care and rectify any fault free of charge unless the workmanship has been disturbed. The Buyer is responsible for ensuring that the warranty on the motorcycle is not affected by the fitting of the Products. On return of any defective Products R&G shall at its option either supply a replacement or refund the purchase money but shall not be liable if the Products have been modified or used or maintained otherwise than in accordance with R&G's or manufacturer's instructions and good engineering practice or if the defect arises from accident or neglect. Other than identified above and subject to R&G not limiting its liability for causing death and personal injury, it shall not be liable for indirect or consequential loss and otherwise its liability shall be limited to the amounts paid by the Buyer for the Products or the fitting or service concerned. These terms do not affect the Buyer's statutory rights.

R&G RACING RETURNS POLICY (NON-FAULTY GOODS)

Returns must be pre-authorized (if not pre-authorized the return will be rejected). Goods may only be returned direct to us if they were purchased direct from us (customer must prove if necessary). Otherwise to be returned to original vendor. Goods must be in re-sellable condition, in the opinion of R&G Racing. All returns are subject to a 25% restocking and handling fee (25% of the gross value exc. P&P – at the prevailing price at time of purchase). The customer must pay any and all carriage charges. No returns of discontinued products, unless within 14 days of purchase. This policy does not affect your statutory rights and does not refer to faulty goods.

R&G

Unit 1, Shelley's Lane, East Worldham, Alton, Hampshire, GU34 3AQ

Tel: +44 (0)1420 89007 Fax: +44 (0)1420 87301 www.rg-racing.com Email: info@rg-racing.com