



LP0172

FITTING INSTRUCTIONS FOR LP0172BK LICENCE PLATE BRACKET
YAMAHA R25 2014-

Page | 1



THIS KIT CONTAINS THE ITEMS PICTURED AND LABELLED BELOW.
DO NOT PROCEED UNTIL YOU ARE SURE ALL PARTS ARE PRESENT.

Please note that the way the kit is packed does not necessarily represent the way of mounting to the bike

THE PARTS SHOWN MAY BE REPRESENTATIVE ONLY (FOR CLARITY OF INSTRUCTIONS ONLY)

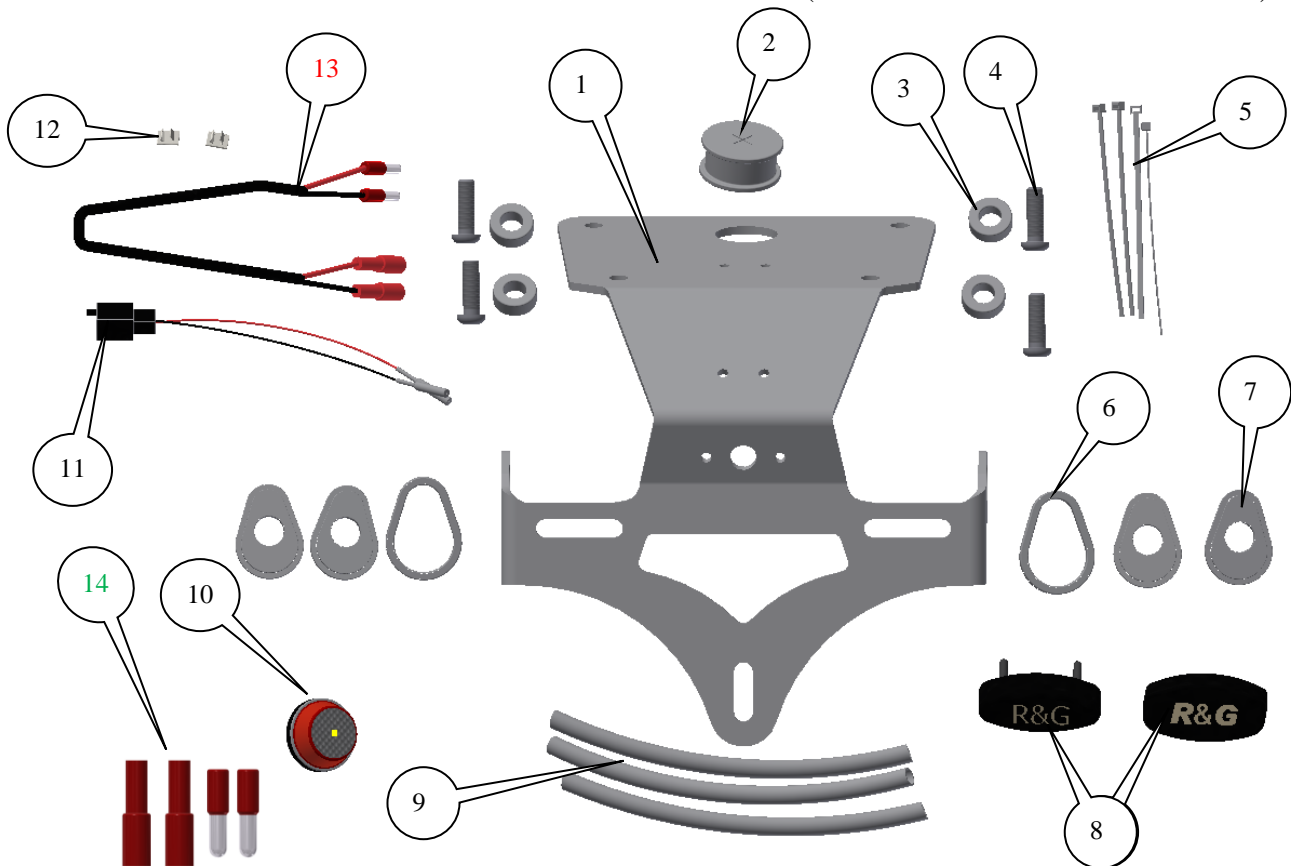

R&G Racing

Unit 1, Shelley's Lane, East Worldham, Alton, Hampshire, GU34 3AQ

Tel: +44 (0)1420 89007 Fax: +44 (0)1420 87301 www.rg-racing.com Email: info@rg-racing.com



LP0172

LEGEND

- ITEM 1 = LICENCE PLATE MOUNTING BRACKET (TB0172BK) (x1).
- ITEM 2 = RUBBER WIRING GROMMET (RB0002) (x1).
- ITEM 3 = MOUNTING SPACERS (S0299) (x4).
- ITEM 4 = M6x20mm BUTTON HEAD BOLTS (x4).
- ITEM 5 = SMALL CABLE TIES LONG (x4).
- ITEM 6 = ORIGINAL INDICATOR SPACERS (I0037) (x2).
- ITEM 7 = MINI INDICATOR ADAPTORS (I0016) (x4).
- ITEM 8 = LICENCE PLATE ILLUMINATOR ASSEMBLY (LA0002) (x1).
- ITEM 9 = 180mm LENGTHS OF HEAT SHRINK (x3).
- ITEM 10 = REFLECTOR (REFL 1) (x1).
- ITEM 11 = LICENCE PLATE ILLUMINATOR CONNECTOR (CON0007) (x1).
- ITEM 12 = SELF ADHESIVE CABLE CLIPS (x2).
- ITEM 13 = R&G MINI INDICATOR CONNECTORS (CON0044) (x2).
- ITEM 14 = LICENCE PLATE ILLUMINATOR CONNECTOR 2019- (CON0004) (x1).

Page | 2

Please note that in cases where kits are packed with rubber washers holding the components onto the bolt – *the rubber washers should be thrown away!*

TOOLS REQUIRED

- Set of metric Allen keys.
- Metric Socket set.
- Phillips driver.
- Small amount of super glue.

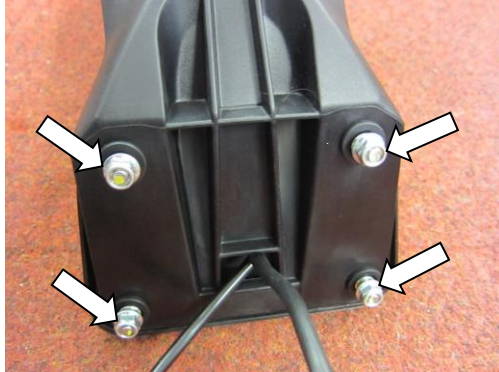

PICTURE 1



PICTURE 2



PICTURE 3

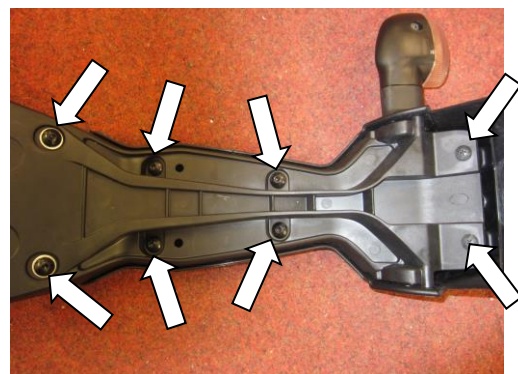

PICTURE 4



LP0172



PICTURE 5

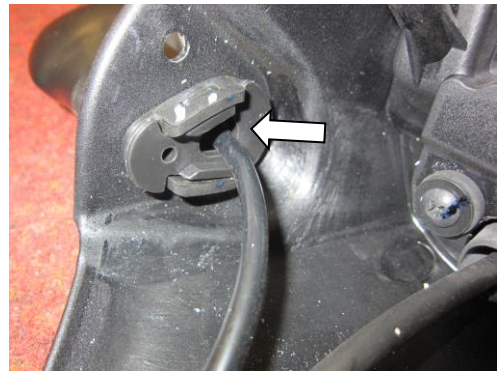

PICTURE 6

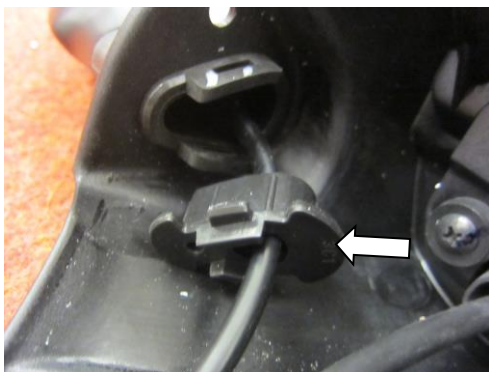

PICTURE 7



PICTURE 8



PICTURE 9

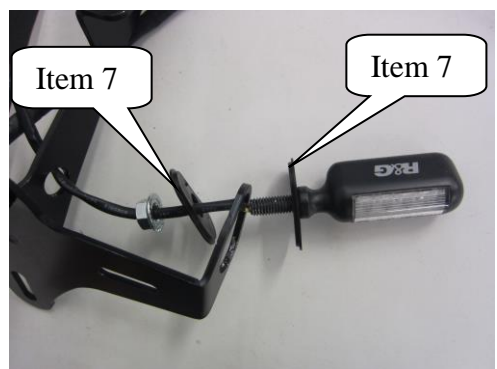

PICTURE 10



LP0172

Page | 4



PICTURE 11



PICTURE 12



PICTURE 13



PICTURE 14



PICTURE 15

FITTING INSTRUCTIONS

- Remove the pillion seat using the key.
- Disconnect the indicator and licence plate illuminator wiring plug sockets.
- Remove the four nuts that hold the original licence plate bracket from under the pillion seat as arrowed in picture 1.
- With the original licence plate bracket removed, remove the two screws arrowed in pictures 2 and 3.
- Remove the four bolts and four screws arrowed in picture 4.

R&G Racing

Unit 1, Shelley's Lane, East Worldham, Alton, Hampshire, GU34 3AQ

Tel: +44 (0)1420 89007 Fax: +44 (0)1420 87301 www.rg-racing.com Email: info@rg-racing.com



LP0172

- Remove the cable cover/support for access to the original indicators and wiring as shown in picture 5.

If using the original indicators

- Remove the spreader/location plate arrowed in pictures 6 and 7.
- Gently squeeze the indicator stem and remove the indicator as shown in picture 8.
- Repeat for the other indicator.
- Fit the original indicators to the new licence plate bracket (item 1) using the indicator adaptors (item 6) (in position arrowed in picture 9 so it fits in the groove in the stem and between the indicator and the bracket) as shown in picture 9.

If fitting R&G mini indicators (R&G product code RG370=bulb, RG371=LED or RG372 = Aero LED

- If fitting the R&G Mini Indicators, use the indicator adaptors (item 7) as shown in picture 10 (use one adaptor either side of the bracket). Connect the R&G Mini Indicators to the wiring loom **using the supplied wiring connectors (item 13) to the original wiring plug socket** and check the operation at this stage (if illumination fails, swap the bullet connections around). (Please use the heat-shrink (item 9) to protect the new indicator wiring).
- Fit the new licence plate illuminator (item 8) to the licence plate bracket assembly as shown in picture 11 (please use the provided heat shrink (item 9) to protect the wiring).
- **PLEASE NOTE YOU WILL NEED TO GLUE THE LIGHT SHROUD TO THE LED LICENCE PLATE ILLUMINATOR USING SUPER GLUE.**
- Push the rubber wiring grommet (item 2) into the larger hole in the licence plate bracket as shown in picture 12.
- Push the wires through the centre of the wiring grommet as shown in pictures 12 and 13.
- Use the self-adhesive clips (item 12) and cable ties (item 5) to tidy and secure the wiring as shown in picture 13.
- Using a small amount of super glue stick the four mounting spacers (item 3) into position as shown in picture 14 (gluing these spacers into position makes the mounting easier).
- Offer the new assembly into position as original while feeding the wires through the under-tray as original and secure using the four button head bolts (item 4) from underneath and the four original nuts as shown in picture 15.
- Reconnect all the indicator wiring plug sockets and check operation (if illumination fails, swap the bullet connections around).
- Connect the licence plate illuminator using the supplied connector (item 11). **If fitting to 2019- model, the OEM licence plate illuminator wiring loom will need to be 'cut and shut' in order to re-use the connector to connect to the main wiring loom. This is done by cutting the connectors off the OEM licence plate illuminator connector (minimum of 50mm away from the connector), peel the end of each wire and fit one female bullet connector (item 14) to each exposed wire. Connect the female bullet connectors just fitted to the male bullet connectors on the R&G licence plate illuminator. It is a good idea to check for illumination at this stage, if illumination fails please swap the bullet connectors over and recheck for correct operation.**
- Fit licence plate to new licence plate bracket (it may require re-drilling).
- **IMPORTANT: IF FITTING A FULL-SIZE LICENCE PLATE AND PLACING IT FAR DOWN ON THE LICENCE PLATE HANGER, THERE IS A SMALL CHANCE OF THE LICENCE PLATE HITTING THE BACK WHEEL UNDER HEAVY LOAD AND OVER LARGE BUMPS IN THE ROAD. IT IS YOUR RESPONSIBILITY TO CHECK FOR THIS POSSIBILITY AND TAKE AVOIDING ACTION. FAILURE TO CHECK THIS COULD RESULT IN SERIOUS INJURY.**
- Refit the seat.



LP0172

- Depending on local laws, attach enclosed red reflector (item 10) in an appropriate location.
- **Please test the indicators, rear light and licence plate illuminator before riding.**

Page | 6

Digital copies of these instructions are available to download from www.rg-racing.com

ISSUE 2 19/08/2016 (NSY)

CONSUMER NOTICE

The catalogue description and any exhibition of samples are only broad indications of the Products and R&G may make design changes which do not diminish their performance or visual appeal and supplying them in such state shall conform to the order. The Buyer acknowledges no representation or warranty (other than as to title) has been given or will apply to the Products other than those in R&G's order or confirmation and the Buyer confirms it has chosen the Products as being of merchantable quality and suitable for its particular purposes. Where R&G fits the Products or undertakes other services it shall exercise reasonable skill and care and rectify any fault free of charge unless the workmanship has been disturbed. The Buyer is responsible for ensuring that the warranty on the motorcycle is not affected by the fitting of the Products. On return of any defective Products R&G shall at its option either supply a replacement or refund the purchase money but shall not be liable if the Products have been modified or used or maintained otherwise than in accordance with R&G's or manufacturer's instructions and good engineering practice or if the defect arises from accident or neglect. Other than identified above and subject to R&G not limiting its liability for causing death and personal injury, it shall not be liable for indirect or consequential loss and otherwise its liability shall be limited to the amounts paid by the Buyer for the Products or the fitting or service concerned. These terms do not affect the Buyer's statutory rights.

R&G RACING RETURNS POLICY (NON-FAULTY GOODS)

Returns must be pre-authorized (if not pre-authorized the return will be rejected). Goods may only be returned direct to us if they were purchased direct from us (customer must prove if necessary). Otherwise to be returned to original vendor. Goods must be in re-sellable condition, in the opinion of R&G Racing. All returns are subject to a 25% restocking and handling fee (25% of the gross value exc. P&P – at the prevailing price at time of purchase). The customer must pay any and all carriage charges. No returns of discontinued products, unless within 14 days of purchase. This policy does not affect your statutory rights and does not refer to faulty goods.

R&G Racing

Unit 1, Shelley's Lane, East Worldham, Alton, Hampshire, GU34 3AQ

Tel: +44 (0)1420 89007 Fax: +44 (0)1420 87301 www.rg-racing.com Email: info@rg-racing.com