



FITTING INSTRUCTIONS FOR CP0407BL
AERO CRASH PROTECTORS FOR TRIUMPH BONNEVILLE T120 '16-, STREET
TWIN '16- & THRUXTON 1200 '16- NON-DRILL KIT



Picture A



Picture B

THIS KIT CONTAINS THE ITEMS PICTURED AND LABELLED BELOW.
DO NOT PROCEED UNTIL YOU ARE SURE ALL PARTS ARE PRESENT.

Please note that the way the kit is packed does not necessarily represent the way of mounting to the bike.

THE PARTS SHOWN MAY BE REPRESENTATIVE ONLY (FOR CLARITY OF INSTRUCTIONS ONLY).

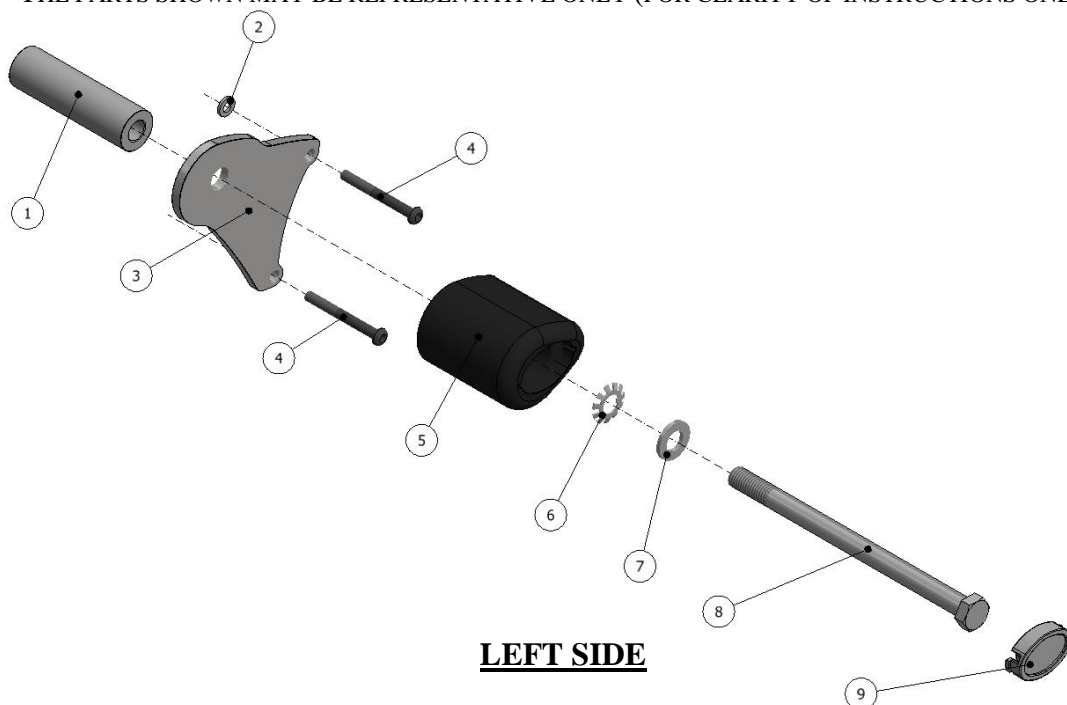

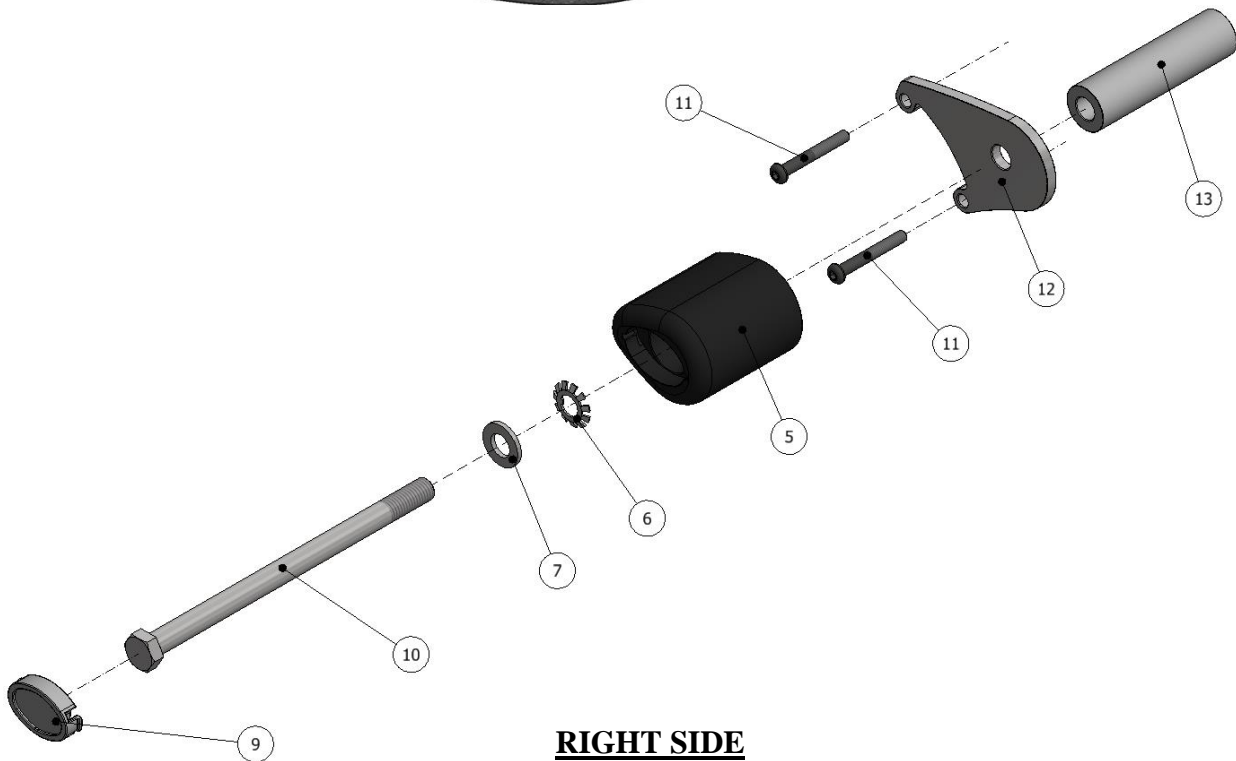

RIGHT SIDE

LEGEND

- ITEM 1 = SPACER (S0969 – 86.50mm LONG) (x1).
 ITEM 2 = M6 WASHER (x1).
 ITEM 3 = MOUNTING PLATE (PLATE 0182) (x1).
 ITEM 4 = M6 x 55mm LONG BUTTON HEAD BOLTS (x2).
 ITEM 5 = CRASH PROTECTOR (B0061 with CS340) (x2).
 ITEM 6 = LOCK-WASHERS (LW0001) (x2).
 ITEM 7 = M12 WASHERS (x2).
 ITEM 8 = M12 x 1.25 x 180mm LONG HEX HEAD BOLT (x1).
 ITEM 9 = CRASH PROTECTOR CAPS (BC0002) (x2).
 ITEM 10 = M12 x 1.25 x 190mm LONG HEX HEAD BOLT (x1).
 ITEM 11 = M6 x 45mm LONG BUTTON HEAD BOLTS (x2).
 ITEM 12 = MOUNTING PLATE (PLATE 0183) (x1).
 ITEM 13 = SPACER (S0970 – 91.50mm LONG) (x1).

Please note that in cases where kits are packed with rubber washers holding the components onto the bolt – *the rubber washers should be thrown away!*

TOOLS REQUIRED

- Socket set to include 4mm AF socket and wrench.
- Socket set to include 8 & 19mm sockets and wrench.
 - T55 Torx socket.
 - 17mm spanner.
- Torque wrench (up to 40N/m).



TOWARDS REAR
OF BIKE

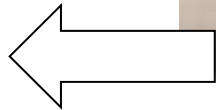

TOWARDS FRONT
OF BIKE

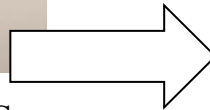

PICTURE C

GENERAL TORQUE SETTINGS

- M4 BOLT = 8Nm
- M5 BOLT = 12Nm
- M6 BOLT = 15Nm
- M8 BOLT = 20Nm
- M10 BOLT = 40Nm

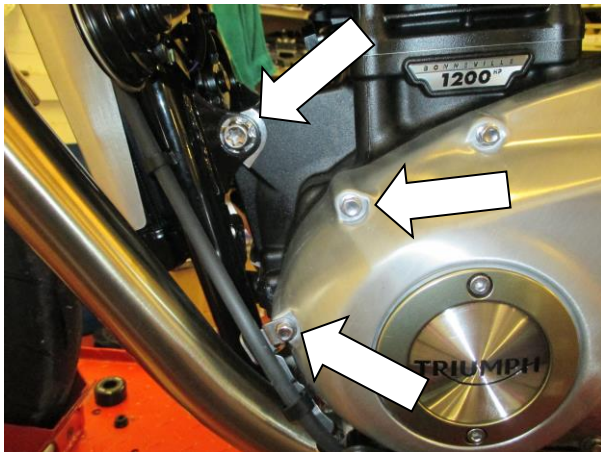

Picture 1



Picture 2



Picture 3



Picture 4

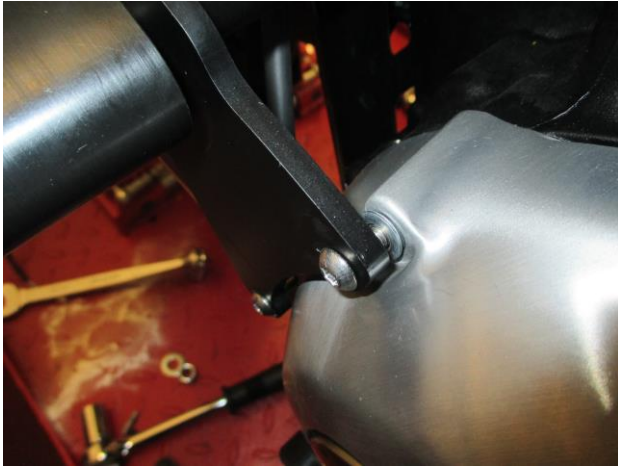

Picture 5



Picture 6

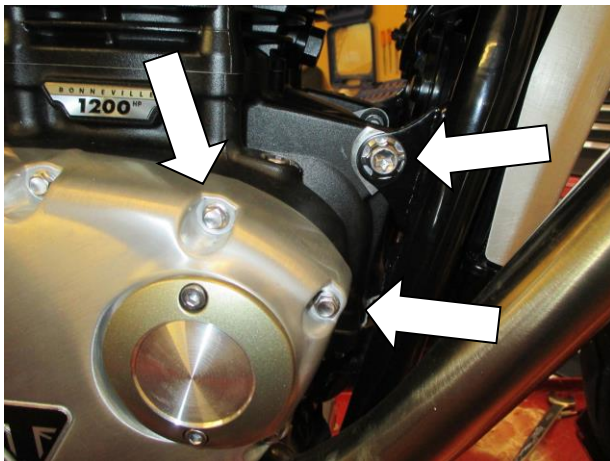

Picture 7



Picture 8

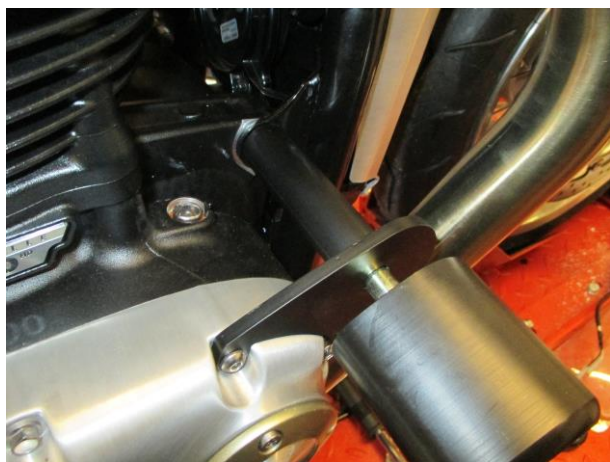

Picture 9

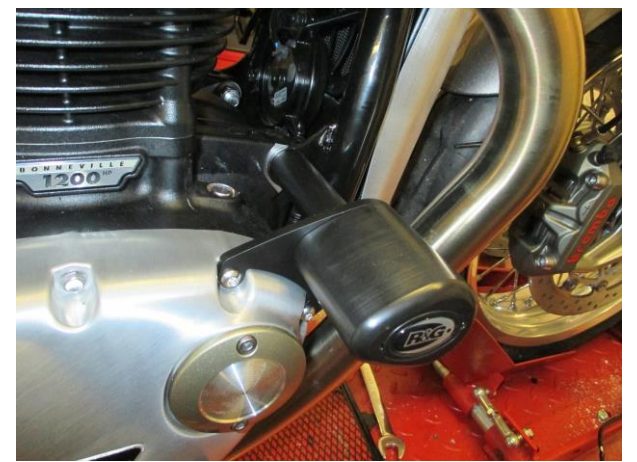

Picture 10