



FITTING INSTRUCTIONS FOR CP0427BL/WH AERO CRASH PROTECTORS
DUCATI SUPERSPORT 2017

Page | 1



PICTURE 'A'



PICTURE 'B'



REAR OF BIKE

FRONT OF BIKE

PICTURE 'C'

THIS KIT CONTAINS THE ITEMS PICTURED AND LABELLED BELOW.
DO NOT PROCEED UNTIL YOU ARE SURE ALL PARTS ARE PRESENT.

Please note that the way the kit is packed does not necessarily represent the way of mounting to the bike

Please note that in cases where kits are packed with rubber washers holding the components onto the bolt – *the rubber washers should be thrown away!*

THE PARTS SHOWN MAY BE REPRESENTATIVE ONLY (FOR CLARITY OF INSTRUCTIONS ONLY)

Digital copies of these instructions are available to download from www.rg-racing.com

GENERAL TORQUE SETTINGS

M4 BOLT = 8Nm
M5 BOLT = 12Nm
M6 BOLT = 15Nm
M8 BOLT = 20Nm
M10 BOLT = 40Nm

R&G Racing

Unit 1 Shelleys Lane, East Worldham, Alton, Hants GU34 3AQ
Tel: +44 (0)1420 89007 Fax: +44 (0)1420 87301 www.rg-racing.com Email: info@rg-racing.com

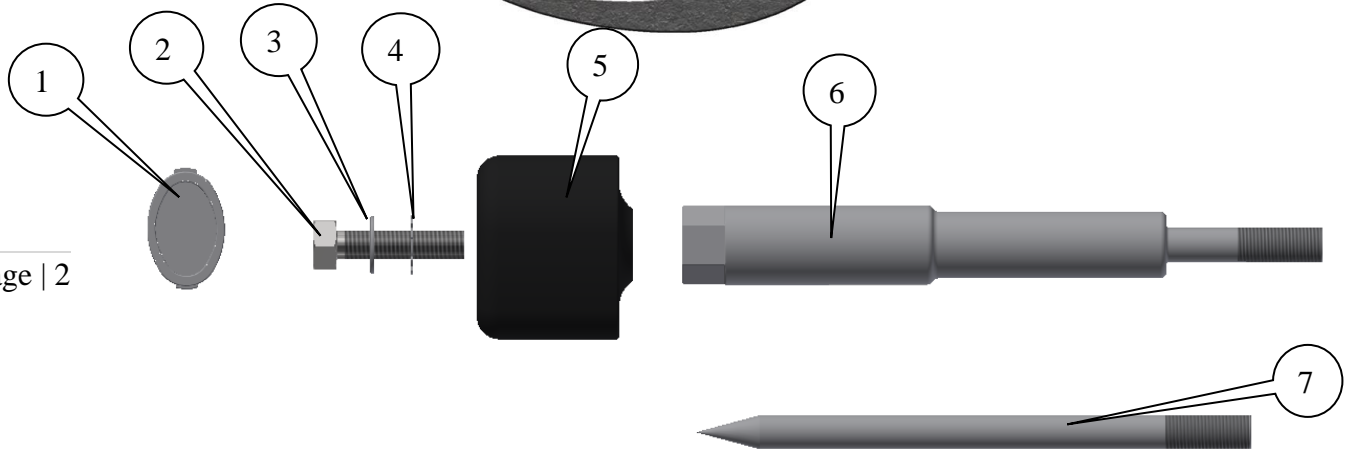

Page | 2

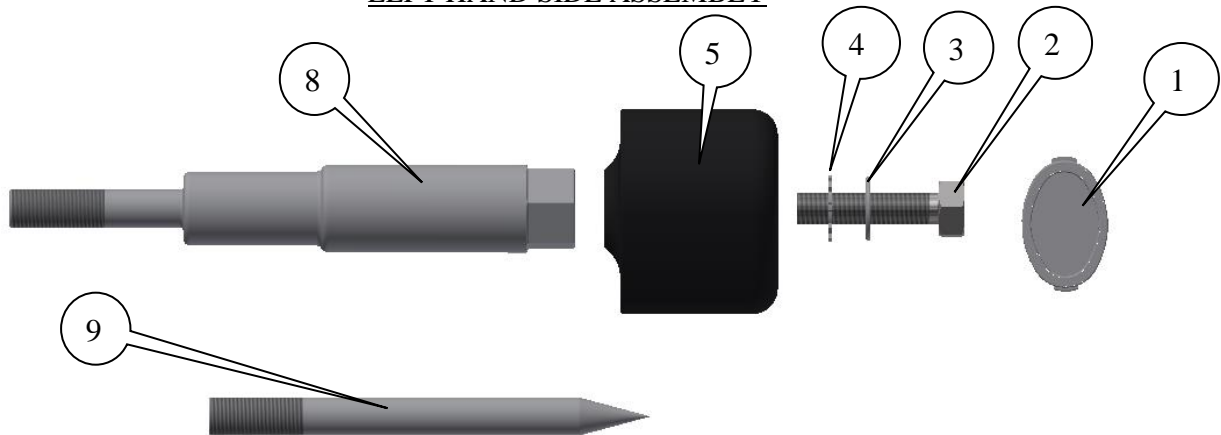
LEFT HAND SIDE ASSEMBLYRIGHT HAND SIDE ASSEMBLYTOOLS REQUIRED

- Socket set to include 14 and 17mm A/F socket and wrench.
 - 2x 24mm Open ended spanners.
 - Hex drive bits or set of Allen keys.
- 28mm Hole-saw and/or dremmel type tool.
 - Torque wrench (up to 40Nm).

LEGEND

ITEM 1 = CRASH PROTECTOR CAPS, L&RHS (BC0002) (x2).

ITEM 2 = CRASH PROTECTOR BOLTS, L&RHS, M10x1.25x45mm LONG HEX HEAD (x2).

ITEM 3 = M10 PLAIN WASHERS, L&RHS (x2).

ITEM 4 = LOCKING WASHERS, L&RHS (LW0001) (x2).

ITEM 5 = CRASH PROTECTORS, L&RHS (B0063 with CS066, 10mm) (x2).

ITEM 6 = CRASH PROTECTOR MOUNTING EXTENSION LHS (E0061=225mm LONG) (x1).

ITEM 7 = MARKING TOOL -LEFT HAND SIDE (T0027=195mm LONG) (x1).

ITEM 8 = CRASH PROTECTOR MOUNTING EXTENSION RHS (E0062=179mm LONG) (x1).

ITEM 9 = MARKING TOOL -RIGHT HAND SIDE (T0028=140mm LONG) (x1).

R&G Racing

Unit 1 Shelleys Lane, East Worldham, Alton, Hants GU34 3AQ

Tel: +44 (0)1420 89007 Fax: +44 (0)1420 87301 www.rg-racing.com Email: info@rg-racing.com



PICTURE 1

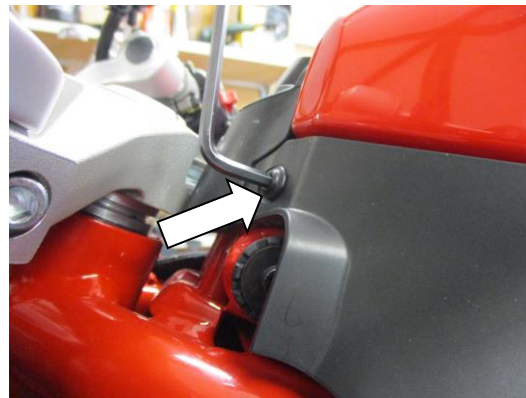

PICTURE 2

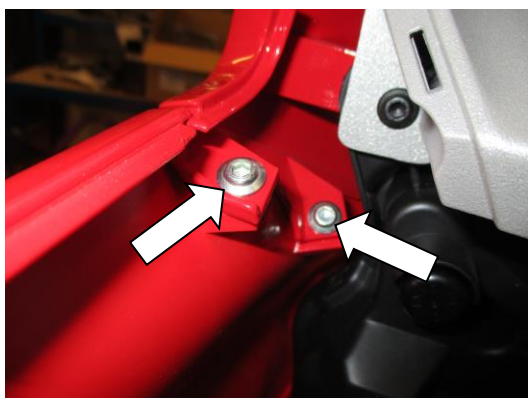

PICTURE 3



PICTURE 4



PICTURE 5



PICTURE 6

R&G Racing

Unit 1 Shelleys Lane, East Worldham, Alton, Hants GU34 3AQ

Tel: +44 (0)1420 89007 Fax: +44 (0)1420 87301 www.rg-racing.com Email: info@rg-racing.com



PICTURE 7



PICTURE 8



PICTURE 9

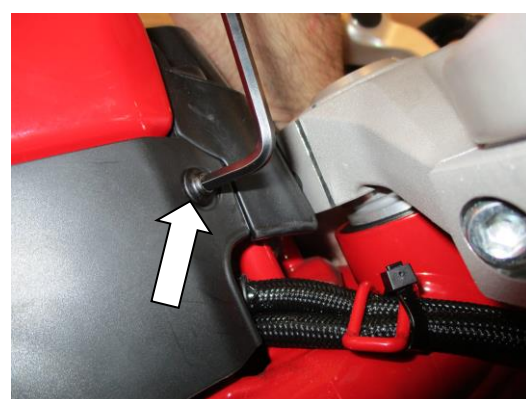

PICTURE 10

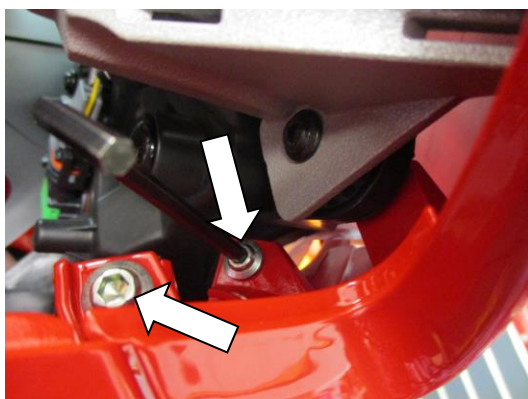

PICTURE 11



PICTURE 12

R&G Racing

Unit 1 Shelleys Lane, East Worldham, Alton, Hants GU34 3AQ

Tel: +44 (0)1420 89007 Fax: +44 (0)1420 87301 www.rg-racing.com Email: info@rg-racing.com



PICTURE 13



PICTURE 14



PICTURE 15



PICTURE 16

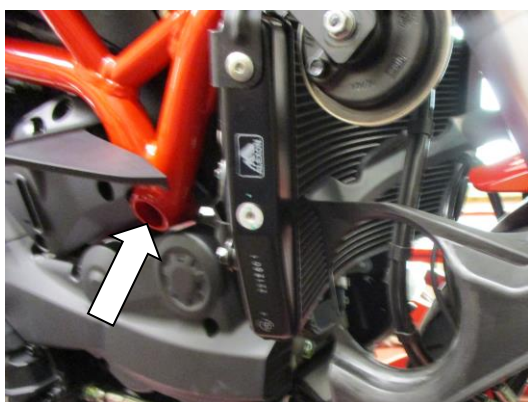

PICTURE 17



PICTURE 18

R&G Racing

Unit 1 Shelleys Lane, East Worldham, Alton, Hants GU34 3AQ

Tel: +44 (0)1420 89007 Fax: +44 (0)1420 87301 www.rg-racing.com Email: info@rg-racing.com

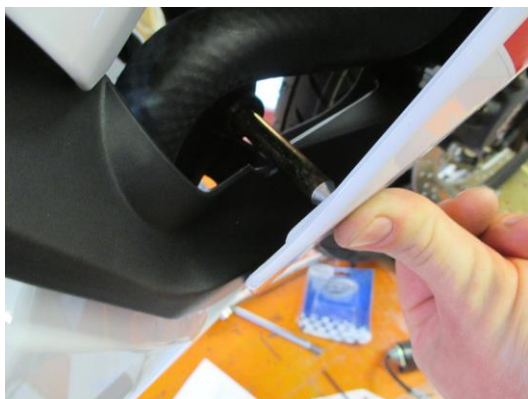

PICTURE 19



PICTURE 20

FITTING INSTRUCTIONS

Near side (left side as you sit on bike)

- Remove the two bolts in position arrowed in pictures 1 and 2.
- Remove the black plastic infill panel to allow access to the side fairing bolts.
- Remove the fairing bolts arrowed in pictures 3, 4, 5, 6, 7 and 8.
- Carefully pull the fairing outwards to disengage the side location spigots and then carefully push forward to disengage front location spigots and remove the fairing.

Off side (right side as you sit on bike)

- Remove the two bolts in position arrowed in pictures 9 and 10.
- Remove the black plastic infill panel to allow access to the side fairing bolts.
- Remove the fairing bolts arrowed in pictures 11, 12, 13, 14 and 15.
- Carefully pull the fairing outwards to disengage the side location spigots and then carefully push forward to disengage front location spigots and remove the fairing.
- Remove the engine bolt arrowed in picture 16 and replace with the shorter marking tool (item 9) engage the tool as far as possible as indicated in picture 18.
- Re-fit the fairing (not all the bolts are required only enough for proper location are required and unscrew the marking tool a little so that it sits against the outer fairing as indicated in pictures 18 and 19. Apply pressure to the outside of the fairing to create a mark on the inside of the fairing from the marking tool (as shown in picture 19), and then remove the fairing once again.
- Using a 28mm tank/cone cutter drill through the fairing with the pilot drill only using the mark to find the centre position of the engine bolt (do not drill full size at this stage).
- Re-fit the fairing and ensure the pilot hole is central to the engine mount hole.
- Remove the fairing and while supporting it carefully drill through the fairing from the outside with the tank cutter.
- Deburr the hole and ensure the shorter extension (item 8) fits through the hole.
- Remove the marking tool from the hole and re-fit the fairing to the right side of the bike.
- With the fairing securely in position fit the shorter extension (item 8) into the engine mount and fully tighten (do not exceed 40N/m of torque).

R&G Racing

Unit 1 Shelleys Lane, East Worldham, Alton, Hants GU34 3AQ

Tel: +44 (0)1420 89007 Fax: +44 (0)1420 87301 www.rg-racing.com Email: info@rg-racing.com



- Place one of the M10 washers (item 3) onto the one of the M10 bolts (item 2) as shown in the right-hand side assembly view.
- Place one of the locking washers (item 4) onto the bolt so it sits against the washer just fitted as shown in the right-hand side assembly view.
- Place the bolt with both washers into the crash protector (item 5) as shown in the right-hand side assembly view.
- Offer this assembly into the threaded hole in the extension as shown in picture 20. Please ensure no parts come in contact with any fairing panels. Finally tighten the crash protector bolts until you feel some compression from inside the protector using 17mm socket and wrench. **PLEASE NOTE THE CRASH PROTECTOR MUST BE POSITIONED AS IN PICTURE 'C' WITH BIGGER END TOWARD FRONT OF BIKE.** Turn a little more so that you feel the compression increase slightly. **Tighten to 40Nm of torque (do not exceed this figure, as damage can occur to the motorcycle and the bolt).**
- If not already fitted, fit bubble sticker into recess of crash protector cap (item 1).
- Fit crash protector cap (item 1) into the crash protector.

Near side (left side as you sit on bike)

- Remove the engine bolt arrowed in picture 17 and replace with the longer marking tool (item 7) engage the tool as far as possible.
- Re-fit the fairing (not all the bolts are required only enough for proper location are required and unscrew the marking tool a little so that it sits against the outer fairing as indicated in pictures 18 and 19. Apply pressure to the outside of the fairing to create a mark on the inside of the fairing from the marking tool (as indicated in picture 19), and then remove the fairing once again.
- Using a 28mm tank/cone cutter drill through the fairing with the pilot drill only using the mark to find the centre position of the engine bolt (do not drill full size at this stage).
- Re-fit the fairing and ensure the pilot hole is central to the engine mount hole.
- Remove the fairing and while supporting it carefully drill through the fairing from the outside with the tank cutter.
- deburr the hole and ensure the longer extension (item 6) fits through the hole.
- Remove the marking tool from the hole and re-fit the fairing to the right side of the bike.
- With the fairing securely in position fit the longer extension (item 6) into the engine mount and fully tighten (**do not exceed 40N/m of torque**).
- Place one of the M10 washers (item 3) onto the one of the M10 bolts (item 2) as shown in the left-hand side assembly view.
- Place one of the locking washers (item 4) onto the bolt so it sits against the washer just fitted as shown in the left-hand side assembly view.
- Place the bolt with both washers into the crash protector (item 5) as shown in the left-hand side assembly view.
- Offer this assembly into the threaded hole in the extension as shown in picture 20. Please ensure no parts come in contact with any fairing panels. Finally tighten the crash protector bolts until you feel some compression from inside the protector using 17mm socket and wrench. **PLEASE NOTE THE CRASH PROTECTOR MUST BE POSITIONED AS IN PICTURE 'C' WITH BIGGER END TOWARD FRONT OF BIKE.** Turn a little more so that you feel the compression increase slightly. **Tighten to 40Nm of torque (do not exceed this figure, as damage can occur to the motorcycle and the bolt).**
- If not already fitted, fit bubble sticker into recess of crash protector cap (item 1).
- Fit crash protector cap (item 1) into the crash protector.

R&G Racing

Unit 1 Shelleys Lane, East Worldham, Alton, Hants GU34 3AQ

Tel: +44 (0)1420 89007 Fax: +44 (0)1420 87301 www.rg-racing.com Email: info@rg-racing.com