



Fitting Instructions For EP0008 EXHAUST PROTECTOR
AKRAPOVIC EXHAUST CANS -



This Kit contains the items pictured and labelled over page.

Some parts may be shown for clarity of instructions only.

Do not proceed until you are sure all parts are present.

Please read all instructions before proceeding.

IF IN ANY DOUBT WHEN FITTING OUR PRODUCTS, CONSULT ONE OF OUR DEALERS OR HAVE FITTED BY A QUALIFIED TECHNICIAN.

Please note that the way the kit is packed does not necessarily represent the way of mounting to the bike.

In the event of rubber washers being used to hold components onto bolts, these rubber washers can be thrown away.

DIGITAL COPIES OF THESE INSTRUCTIONS ARE AVAILABLE FROM

www.rg-racing.com

R&G Racing

Unit 1, Shelleys Lane, East Worldham, Alton, Hampshire GU34 3AQ.

Tel: +44 (0)1420 89007 Fax +44 (0)1420 87301 www.rg-racing.com Email: info@rg-racing.com



<u>TOOLS REQUIRED</u>	<u>GENERAL TORQUE SETTINGS</u>
<ul style="list-style-type: none"> 8MM SOCKET AND ATTACHMENT 	<p>M4 BOLT = 8Nm M5 BOLT = 12Nm M6 BOLT = 15Nm M8 BOLT = 20Nm M10 BOLT = 40Nm M12 BOLT = 40Nm</p>

LEGEND

ITEM NO.	DESCRIPTION	QTY
ITEM 1	EXHAUST PROTECTOR WITH JUBILEE BAND	1
ITEM 2	SILICON BAND BACKING STRIP	1
ITEM 3	SILICON EXHAUST PROTECTOR BACKING STRIP	1

Assembly diagram

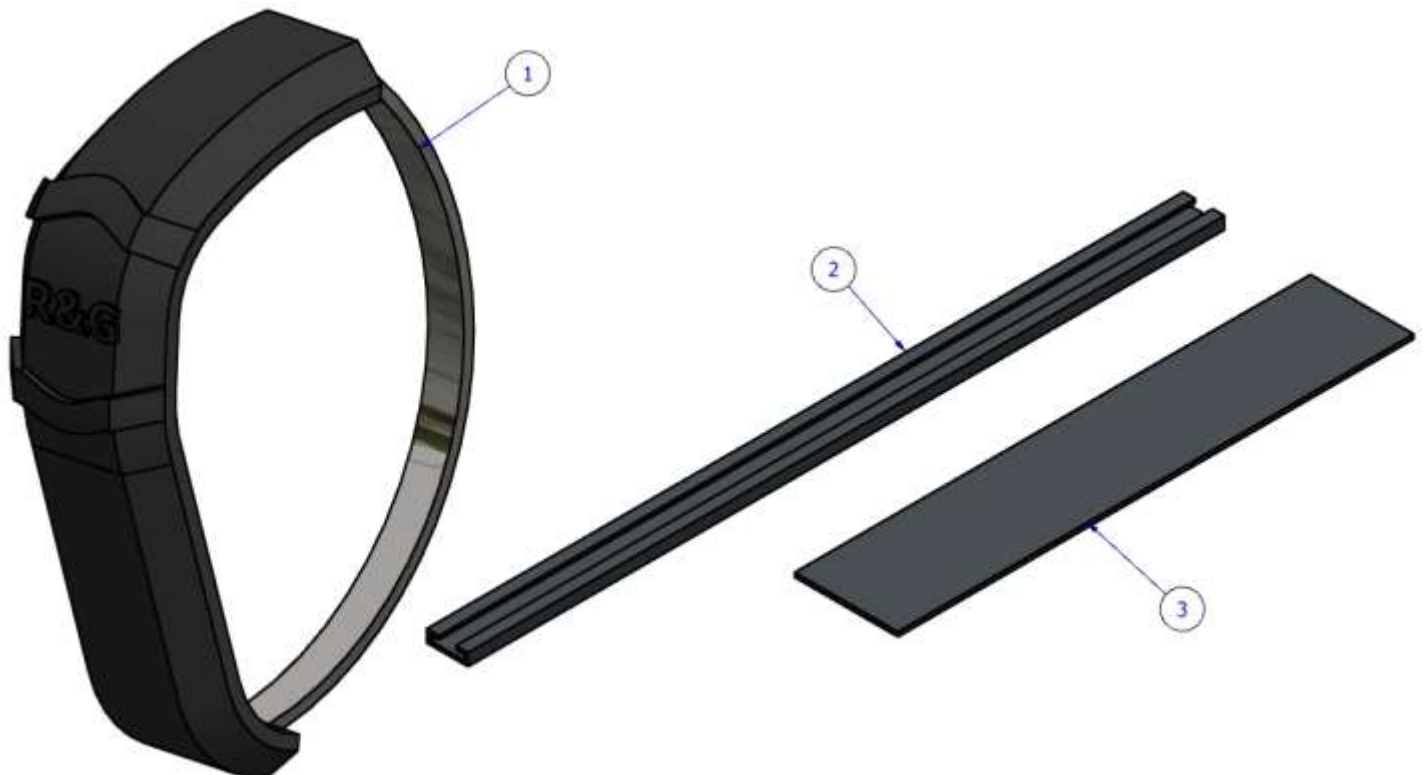

R&G Racing

Unit 1, Shelleys Lane, East Worldham, Alton, Hampshire GU34 3AQ.

Tel: +44 (0)1420 89007 Fax +44 (0)1420 87301 www.rg-racing.com Email: info@rg-racing.com



FITTING INSTRUCTIONS

- First, take the thinner silicone backing strip (item 2) and wrap over the steel jubilee band of the exhaust protector (item 1) so that the back of the band is covered to protect the exhaust when fitted. Trim this to length if necessary.
- Offer up the exhaust protector (item 1) to the exhaust. If necessary, rotate the band so that the fastening section will not interfere with the swingarm or other moving parts of the bike when fitted.
- Place wider silicone strip (item 3) around the exhaust can, in the position intended for the exhaust protector.
- Depending on the desired location of the exhaust protector, loosen the band and slide over the exhaust, or if necessary, open the jubilee clip completely and wrap around the exhaust over the wider section of silicone in the chosen position.
- Using your 8mm socket and attachment, tighten the band around the exhaust ensuring that both silicone strips remain in place and that the exhaust protector profile fits neatly against the exhaust and the exhaust protector is secure. **DO NOT OVERTIGHTEN.**
- When tightening the exhaust protector band, make sure the loose end tucks neatly into the base of the exhaust protector.

Please note that it is your responsibility to ensure that no part of the exhaust protector assembly fouls or comes into contact with other parts of the machine. Do not ride the motorcycle until this aspect has been verified and you have compressed the rear suspension (if appropriate to the design of the motorcycle) to test this thoroughly.

Issue 1 12/09/2019 (DM)

CONSUMER NOTICE

The catalogue description and any exhibition of samples are only broad indications of the Products and R&G may make design changes which do not diminish their performance or visual appeal and supplying them in such state shall conform to the order. The Buyer acknowledges no representation or warranty (other than as to title) has been **given or will apply to the Products other than those in R&G's order or confirmation and the Buyer confirms it has chosen the Products as being of merchantable quality and suitable for its particular purposes.** Where R&G fits the Products or undertakes other services it shall exercise reasonable skill and care and rectify any fault free of charge unless the workmanship has been disturbed. The Buyer is responsible for ensuring that the warranty on the motorcycle is not affected by the fitting of the Products. On return of any defective Products R&G shall at its option either supply a replacement or refund the purchase money but shall not be liable if the Products have been modified or used or **maintained otherwise than in accordance with R&G's or manufacturer's instructions and good engineering practice** or if the defect arises from accident or neglect. Other than identified above and subject to R&G not limiting its liability for causing death and personal injury, it shall not be liable for indirect or consequential loss and otherwise its liability shall be limited to the amounts paid by the Buyer for the Products or the fitting or service concerned. These terms do **not affect the Buyer's statutory rights.**

R&G RACING RETURNS POLICY (NON-FAULTY GOODS)

Returns must be pre-authorized (if not pre-authorized the return will be rejected). Goods may only be returned direct to us if they were purchased direct from us (customer must prove if necessary). Otherwise to be returned to original vendor. Goods must be in re-sellable condition, in the opinion of R&G Racing. All returns are subject to a 25% re-stocking and handling fee (25% of the gross value exc. P&P – at the prevailing price at time of purchase). The customer must pay any and all carriage charges. No returns of discontinued products, unless within 14 days of purchase. This policy does not affect your statutory rights and does not refer to faulty goods.

R&G Racing

Unit 1, Shelleys Lane, East Worldham, Alton, Hampshire GU34 3AQ.

Tel: +44 (0)1420 89007 Fax +44 (0)1420 87301 www.rg-racing.com Email: info@rg-racing.com