



FITTING INSTRUCTIONS FOR LP0320BK LICENCE PLATE BRACKET
TRIUMPH SPEED TRIPLE 1200 RS 2021-



This kit contains the items pictured and labelled over page.

Some parts may be shown for clarity of instructions only.

Do not proceed until you are sure all parts are present.

Please read all instructions before proceeding.

IF IN ANY DOUBT WHEN FITTING OUR PRODUCTS, CONSULT ONE OF OUR DEALERS
OR HAVE FITTED BY A QUALIFIED TECHNICIAN.

Please note that the way the kit is packed does not necessarily represent the way of mounting to the bike.

In the event of rubber washers being used to hold components onto bolts, these rubber washers can be thrown away.

DIGITAL COPIES OF THESE INSTRUCTIONS ARE AVAILABLE FROM

WWW.RG-RACING.COM

R&G

Unit 1, Shelley's Lane, East Worldham, Alton, Hampshire, GU34 3AQ

Tel: +44 (0)1420 89007 Fax: +44 (0)1420 87301 www.rg-racing.com Email: info@rg-racing.com



<u>TOOLS REQUIRED</u>	<u>GENERAL TORQUE SETTINGS</u>
<ul style="list-style-type: none"> • Set of Torx keys or sockets including T20, T25, T30. • Set of metric Allen keys to include 5 & 6mm <ul style="list-style-type: none"> • Phillips screwdriver. • Small flat head screwdriver. 	<p>M4 BOLT = 8Nm</p> <p>M5 BOLT = 12Nm</p> <p>M6 BOLT = 15Nm</p> <p>M8 BOLT = 20Nm</p> <p>M10 BOLT = 40Nm</p> <p>M12 BOLT = 40Nm</p>

LEGEND

ITEM No.	DESCRIPTION	QTY
ITEM 1	TB0320BK PART 1 - MAIN BRACKET RHS	1
ITEM 2	TB0320BK PART 2 - MAIN BRACKET LHS	1
ITEM 3	TB0320BK PART 3 - LICENSE PLATE BRACKET	1
ITEM 4	S1360 - MOUNTING SPACERS	4
ITEM 5	CON0065 - LICENCE PLATE ILLUMINATOR CONNECTOR	1
ITEM 6	CON0046 - INDICATOR CONNECTOR	2
ITEM 7	LA0002 - NUMBER PLATE LIGHT ASSEMBLY	1
ITEM 8	M5x0.8x10.0 mm COUNTER SUNK SCREWS	4
ITEM 9	M5x0.8 NYLOC NUTS	4
ITEM 10	M5x10mm WASHERS	4
ITEM 11	REFL 3 - REFLECTOR	1
ITEM 12	150mm LENGTH OF HEATSHRINK	3
ITEM 13	2.5mm CABLE TIES	6
ITEM 14	IWC0002 - MINI INDICATOR WIRING COVERS	2
ITEM 15	CLIP 1 - SELF ADHEISIVE CABLE CLIPS	2

R&G

Unit 1, Shelley's Lane, East Worldham, Alton, Hampshire, GU34 3AQ

Tel: +44 (0)1420 89007 Fax: +44 (0)1420 87301 www.rg-racing.com Email: info@rg-racing.com



ASSEMBLY DIAGRAM 1

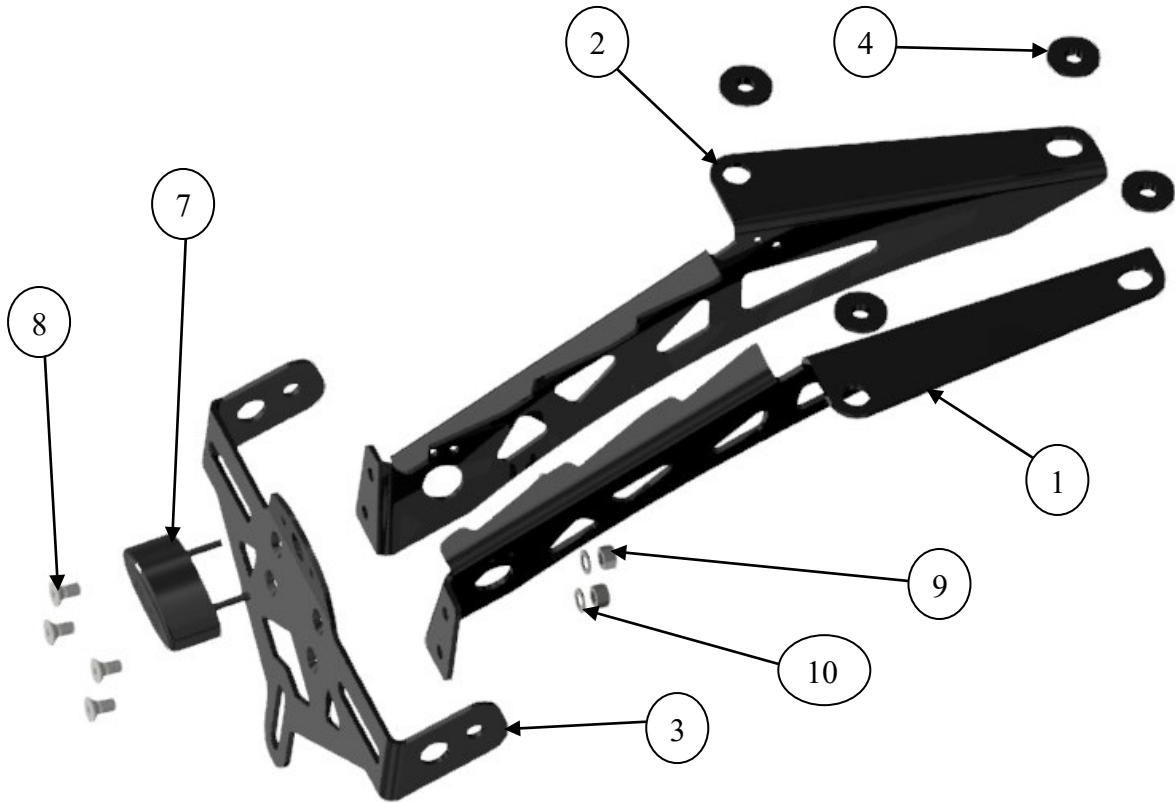

FITTING PICTURES



Picture 1

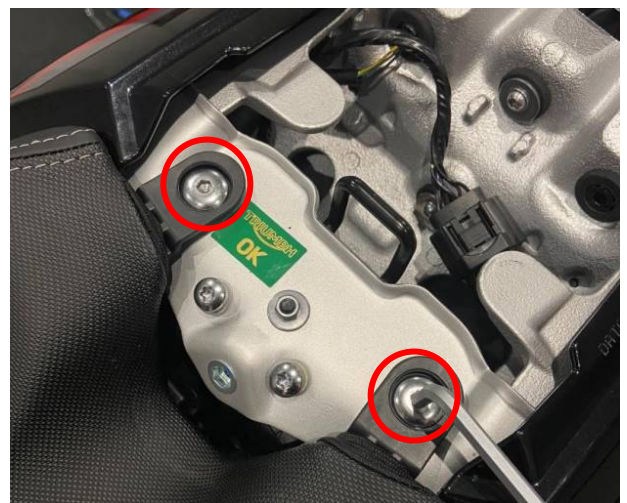

Picture 2

R&G



Picture 3

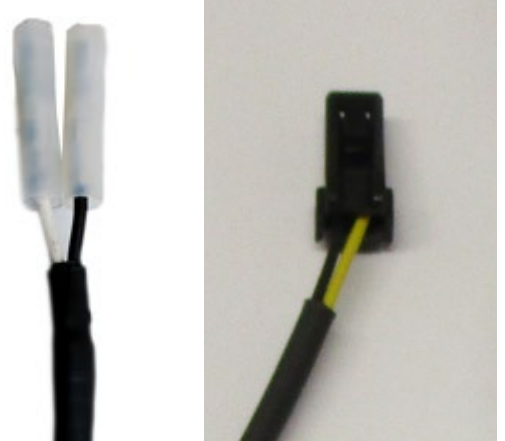

Picture 4

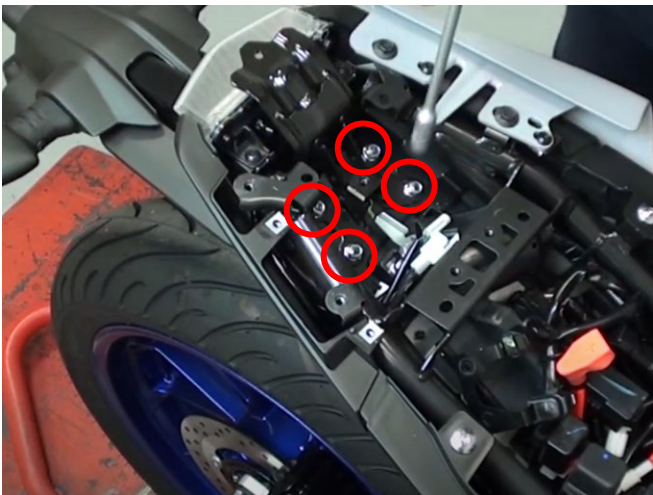

Picture 5



Picture 6





Picture 7



Picture 8



Picture 9



Picture 11



Picture 12

R&G



FITTING INSTRUCTIONS

- To fit the R&G tail tidy, remove the seat from the bike using the key under the tail unit as shown in **Picture 1**.
- Remove the 2 bolts also shown in **Picture 1**, using a 10mm socket or spanner.
- Remove the 4 bolts shown in **Picture 2** using a 4 & 5mm Allen key.
- The tail unit right-hand-side panel can now be removed from the tail unit in order to free the cables to the indicators and rear light.
- Next, Remove the 3 bolts shown in in **Picture 3**, to remove the fuse bracket and seat lock mechanism plate.
- Unplug the indicator and illuminator cables with a small screwdriver to free the connectors shown in **Picture 4**.
- The 4 nuts in **Picture 5** can now be removed, which frees the support bracket and bolts holding the original license plate holder in place. Keep these 4 nuts safe as they will be re-used on the R&G tail tidy.
- Carefully remove the cables attached to the original license plate holder through the small hole in the underside of the tail unit.
- With the original license plate holder removed, you must first assemble the R&G tail tidy before it can be attached.
- Secure Item 2 (License plate mount plate) to Item 3 (Cover plate) using an M5 countersunk screw. Tighten with an M5 washer and nyloc nut.
- Next, attach Item 1 (Main bracket) to Item 2 (License plate mount plate) as shown in **Picture 8**, with the same M5 screws, washers and nuts shown in **Picture 9**.
- If using the original indicators, these can be removed from the original license plate holder and attached to the R&G tail tidy using the OEM indicator adaptors (Item 5)
- If using R&G or other indicators, Item 4 (indicator adaptors) can be used to attach these.
- Attach the License plate illuminator (Item 9) to the tail tidy through the holes shown in **Picture 10**.
- Attach the illuminator connector (left side of **Picture 4**) to the bullet connections on the R&G illuminator wires. If using R&G or other indicators, attach the indicator connectors (right side of **Picture 4**) to the bullet connections on the indicator wires.
- Route the indicator and illuminator wires through the centre of the tail tidy between the main bracket and the cover plate until they are exposed at the main mounting area.

R&G

Unit 1, Shelley's Lane, East Worldham, Alton, Hampshire, GU34 3AQ

Tel: +44 (0)1420 89007 Fax: +44 (0)1420 87301 www.rg-racing.com Email: info@rg-racing.com



- The R&G tail tidy can now be offered up to the mounting holes on the underside of the tail unit. At this time route the cables through the hole where they were removed previously.
- Insert the M6 bolts and secure the tail tidy in place while reattaching the support bracket shown in **Picture 5**.
- Tighten the 4 M6 screws with the M6 washers and the nuts which were removed from the original licence plate holder as shown in **Picture 5**.
- Re-connect the illuminator and indicator wires, ensuring that the left and right sides are connected correctly respectively.
- The fuse bracket and seat catch mechanism plates can now be re-attached using the same bolts removed in **Picture 3**.
- Now the tail right-hand-side panel can be re-attached by first fastening the bolts shown in **Picture 2**, and then fastening the screws shown in **Picture 1**.
- The seat can then be re-attached, ensuring that it positively clicks into place and is secured by the locking mechanism.
- The Rubber bung provided (Item 6) can be used to cover the seat key lock and keep it free from dirt and water. Push it over the lock barrel and it will stay in place. Note that the key lock can be operated with the rubber bung in place.

IMPORTANT: IF FITTING A FULL-SIZE LICENCE PLATE AND PLACING IT FAR DOWN ON THE LICENCE PLATE HANGER, THERE IS A SMALL CHANCE OF THE LICENCE PLATE HITTING THE BACK WHEEL UNDER HEAVY LOAD AND OVER LARGE BUMPS IN THE ROAD. IT IS YOUR RESPONSIBILITY TO CHECK FOR THIS POSSIBILITY AND TAKE AVOIDING ACTION. FAILURE TO CHECK THIS COULD RESULT IN SERIOUS INJURY.

ISSUE 1 - 02/07/2021 - (WW)

CONSUMER NOTICE

The catalogue description and any exhibition of samples are only broad indications of the Products and R&G may make design changes which do not diminish their performance or visual appeal and supplying them in such state shall conform to the order. The Buyer acknowledges no representation or warranty (other than as to title) has been given or will apply to the Products other than those in R&G's order or confirmation and the Buyer confirms it has chosen the Products as being of merchantable quality and suitable for its particular purposes. Where R&G fits the Products or undertakes other services it shall exercise reasonable skill and care and rectify any fault free of charge unless the workmanship has been disturbed. The Buyer is responsible for ensuring that the warranty on the motorcycle is not affected by the fitting of the Products. On return of any defective Products R&G shall at its option either supply a replacement or refund the purchase money but shall not be liable if the Products have been modified or used or maintained otherwise than in accordance with R&G's or manufacturer's instructions and good engineering practice or if the defect arises from accident or neglect. Other than identified above and subject to R&G not limiting its liability for causing death and personal injury, it shall not be liable for indirect or consequential loss and otherwise its liability shall be limited to the amounts paid by the Buyer for the Products or the fitting or service concerned. These terms do not affect the Buyer's statutory rights.

R&G RACING RETURNS POLICY (NON-FAULTY GOODS)

Returns must be pre-authorized (if not pre-authorized the return will be rejected). Goods may only be returned direct to us if they were purchased direct from us (customer must prove if necessary). Otherwise to be returned to original vendor. Goods must be in re-sellable condition, in the opinion of R&G Racing. All returns are subject to a 25% restocking and handling fee (25% of the gross value exc. P&P – at the prevailing price at time of purchase). The customer must pay any and all carriage charges. No returns of discontinued products, unless within 14 days of purchase. This policy does not affect your statutory rights and does not refer to faulty goods.

R&G

Unit 1, Shelley's Lane, East Worldham, Alton, Hampshire, GU34 3AQ

Tel: +44 (0)1420 89007 Fax: +44 (0)1420 87301 www.rg-racing.com Email: info@rg-racing.com