



FITTING INSTRUCTIONS FOR LP0359BK LICENCE PLATE BRACKET



**This kit contains the items pictured and labelled over page.
Some parts may be shown for clarity of instructions only.
Do not proceed until you are sure all parts are present.
Please read all instructions before proceeding.**

**IF IN ANY DOUBT WHEN FITTING OUR PRODUCTS, CONSULT ONE OF OUR DEALERS
OR HAVE FITTED BY A QUALIFIED TECHNICIAN.**

Please note that the way the kit is packed does not necessarily represent the way of mounting to the bike.

In the event of rubber washers being used to hold components onto bolts, these rubber washers can be thrown away.

DIGITAL COPIES OF THESE INSTRUCTIONS ARE AVAILABLE FROM

WWW.RG-RACING.COM

R&G

Unit 1, Shelley's Lane, East Worldham, Alton, Hampshire, GU34 3AQ
Tel: +44 (0)1420 89007 Fax: +44 (0)1420 87301 www.rg-racing.com Email: info@rg-racing.com



<u>TOOLS REQUIRED</u>	<u>GENERAL TORQUE SETTINGS</u>
<ul style="list-style-type: none"> • Set of metric Hex keys to include 5mm & 6mm. • Set of metric sockets and wrench. To include 8mm, 10mm & 12mm. <ul style="list-style-type: none"> • Cable cutters 	M4 BOLT = 8Nm M5 BOLT = 12Nm M6 BOLT = 15Nm M8 BOLT = 20Nm M10 BOLT = 40Nm M12 BOLT = 40Nm

LEGEND

ITEM No.	DESCRIPTION	QTY
ITEM 1	TB0297 PART 1 LICENCE PLATE BRACKET	1
ITEM 2	M0765 BRACKET MOUNTING BLOCK	1
ITEM 3	RG0036 FENDER MOUNTING RUBBER GASKET	1
ITEM 4	I0066 INDICATOR MOUNTING SPACERS	2
ITEM 5	S0994 - TAIL BRACKET LOWER MOUNTING SPACER	1
ITEM 6	M6 x 1.00 x 30mm COUNTERSINK BOLTS	2
ITEM 7	M6 x 1.00 x 30mm BUTTON HEAD BOLT	1
ITEM 8	M6 x 19mm OD WASHER	1
ITEM 9	M6 x 12mm OD WASHERS	3
ITEM 10	M6 NYLOC NUTS	3
ITEM 11	LA0007 BRAKE & LICENCE PLATE LIGHT	1
ITEM 12	LH0005 LIGHT HOUSING/ COVER & FITTING KIT	1
ITEM 13	CON0025 - LIGHT UNIT CONNECTOR	1
ITEM 14	150MM LENGTH OF HEAT SHRINK	4
ITEM 15	CT100 CABLE TIES	4
ITEM 16	REFL3 - REFLECTOR	1
ITEM 17	CON0009 BRAKE LIGHT CONNECTOR	1
ITEM 18	CON0084 LICENCE PLATE LIGHT	1

R&G

Unit 1, Shelley's Lane, East Worldham, Alton, Hampshire, GU34 3AQ

Tel: +44 (0)1420 89007 Fax: +44 (0)1420 87301 www.rg-racing.com Email: info@rg-racing.com



ASSEMBLY DIAGRAM

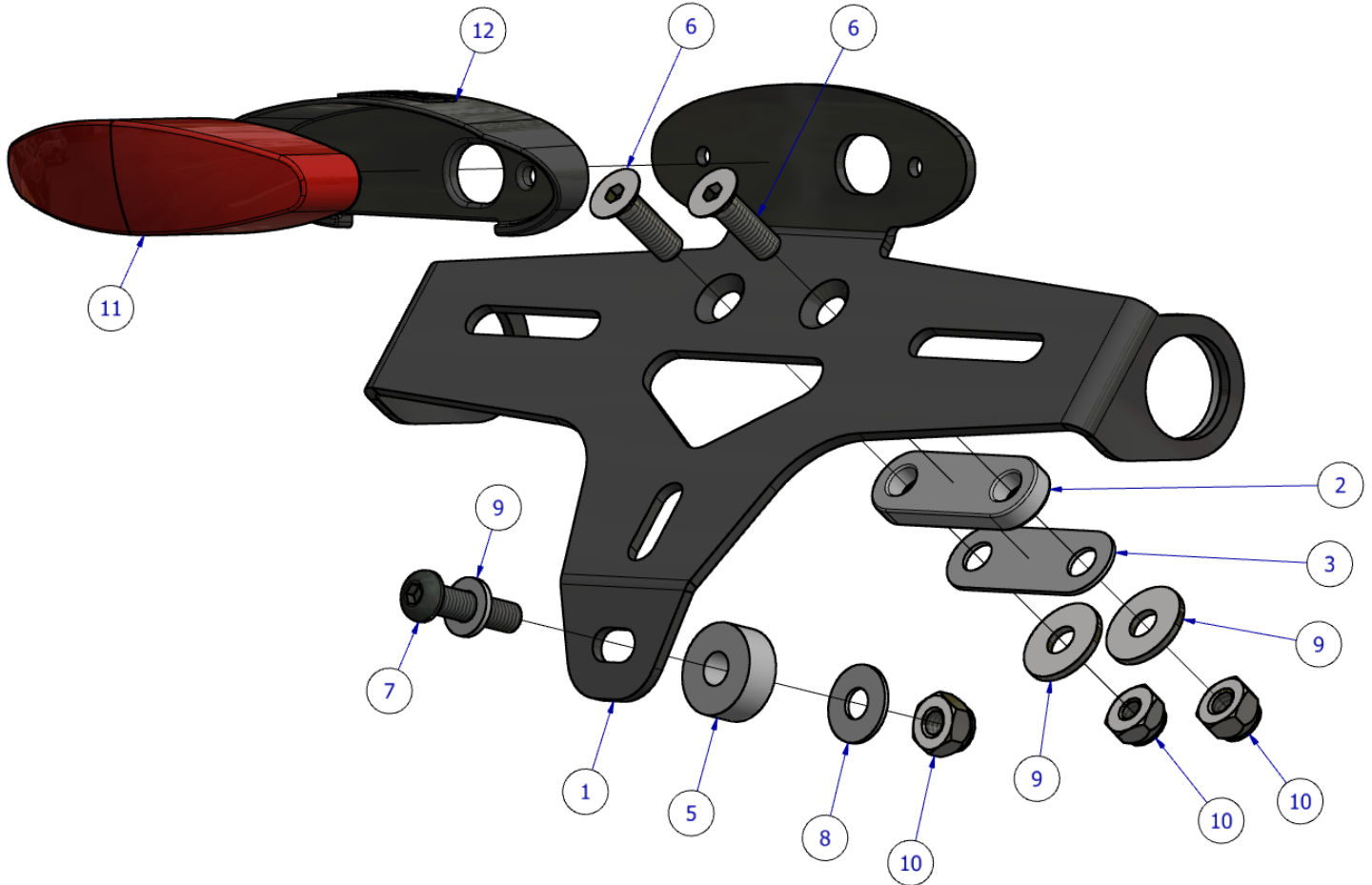

ANCILLARY COMPONENTS

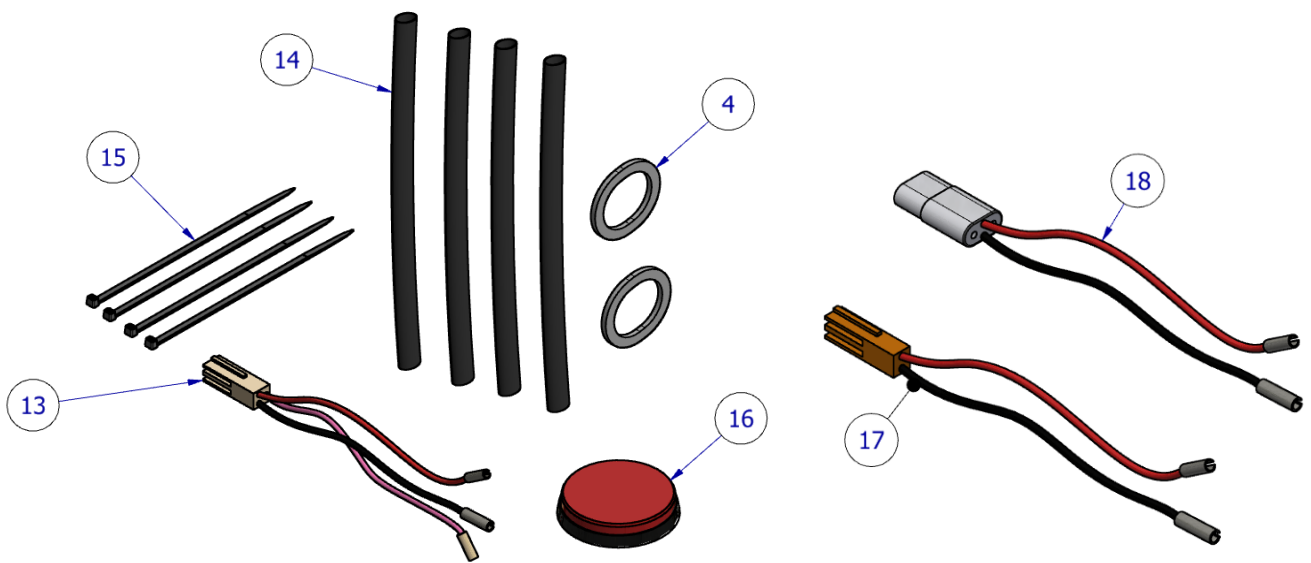

R&G

Unit 1, Shelley's Lane, East Worldham, Alton, Hampshire, GU34 3AQ

Tel: +44 (0)1420 89007 Fax: +44 (0)1420 87301 www.rg-racing.com Email: info@rg-racing.com



Picture 1



Picture 2



Picture 3



Picture 4



Picture 5

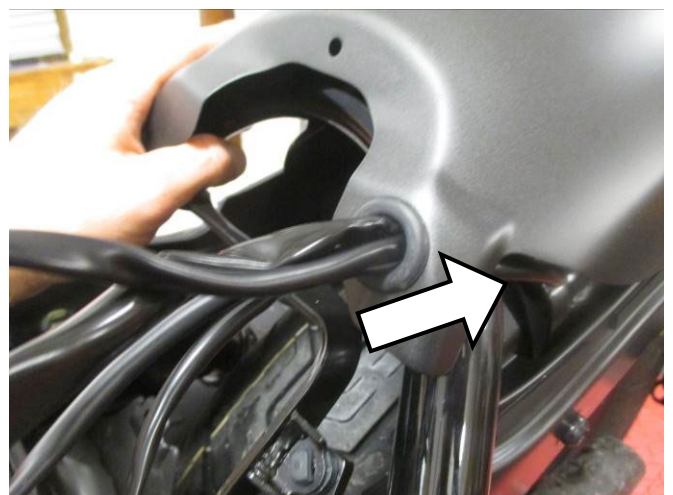

Picture 6

R&G



Picture 7

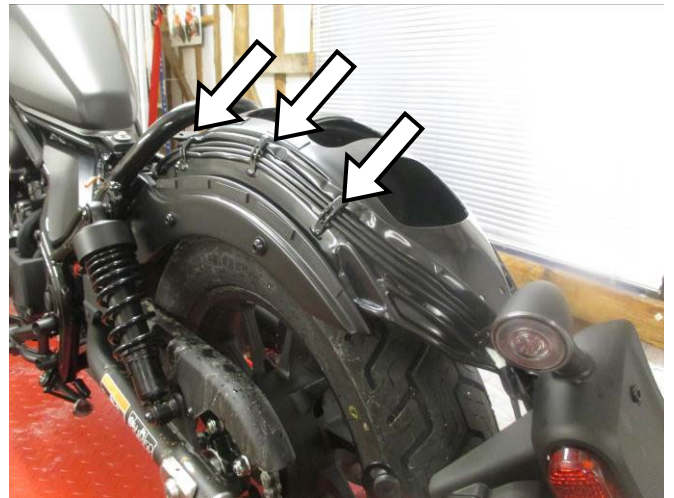

Picture 8



Picture 9



Picture 10



R&G



Picture 11

Picture 12



Picture 13

Picture 14

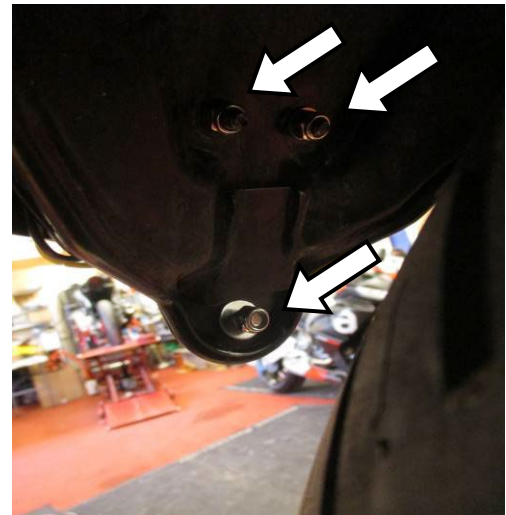

Picture 15

Picture 16



Picture 17



Picture 18

FITTING INSTRUCTIONS

- To fit the R&G tail tidy, remove the rear seat using a 6mm Hex key as in **Picture 1**.
- Remove the rider's seat from the bike using a 5mm allen key to remove both seat bolts as shown in **Picture 2**.
- Remove the 2x retaining nuts for the OEM tail unit using a 10mm socket from the inside of the rear fender as shown in **picture 3**.
- Remove the lower bolt from the OEM tail unit using a 12mm socket and carefully remove the OEM tail light unit so only the wires connect the unit to the bike.
- Remove the 3 push pins from the plastic panel underneath the seat arrowed in **picture 4** by depressing the pins and removing the outer sleeve. Release the panel upwards and out of the bike.
- Locate the connector housing and remove the 3 connectors for the rear light unit and indicators as shown in **picture 5**.
- Remove the wires from the rear fender by threading them through the rubber bung on the LHS of the bike as shown in **picture 6**.
- The rear fender panel can now be removed from the bike, ensure no fasteners remain in the rear fender and carefully lift the piece up and off the subframe as shown in **picture 7**. note, this piece is rubber mounted so may require some manoeuvring to release.
- With the fender removed, support the OEM tail unit and carefully release the indicator and rear light wires from the cable retaining clips shown in **picture 8** to release the unit from the bike as in **picture 9**.
- To release the indicators, for each side, depress the pop pin as shown in **picture 10**.
- Remove the plastic locator block and slide away from the indicator rubber as seen in picture 11.
- Carefully squeeze the indicator rubber and pop this out of the OEM tail unit as shown in picture 12, ensuring to note which side each indicator was removed from.

Tail Tidy Assembly

The following steps refer to the **Assembly Diagram** on page 3.

- Locate the R&G LA0007 rear light unit (**item 11**) into the Light shroud (**item 12**) and affix to the TB0297 Tail Bracket (**item 1**). Ensure the licence plate light faces downwards.

R&G

Unit 1, Shelley's Lane, East Worldham, Alton, Hampshire, GU34 3AQ

Tel: +44 (0)1420 89007 Fax: +44 (0)1420 87301 www.rg-racing.com Email: info@rg-racing.com



- Relocate the OEM indicators into the R&G tail unit by locating the rubber into the tail bracket ensuring to locate the indicators to the corresponding sides as they were removed.
- Thread one I0066 indicator adaptor (**item 4**) over the indicator wire and locate over the rubber as shown in **picture 13**.
- Relocate the plastic indicator block and secure with the pop pin to secure the indicator to the bracket in the same way as removed.

Tail Tidy Fitting

- Use the CON0025 (**item 13**) and connect this in the connector block in place of the OEM taillight connection as shown in **picture 14**.
- With light and indicators fitted to the tail bracket offer up the tail tidy to the bike and locate the wires from the indicators and rear light unit and secure them to the bike using the wire stays as before in **picture 8**, ensuring enough slack is left to connect the light unit to the connector just fitted.
- Neaten the wiring using the cable ties provided (**item 15**) to keep these from being trapped when re-fitting the fender.
- Re-fit the metal fender onto the subframe, ensuring to place the connectors and extra wire through the rubber bung in the fender as removed in **picture 6**.
- Following the **assembly diagram** on page 3, place 2 x M6x20mm countersunk bolts (**item 6**) through the tail bracket.
- Next, place the TB0297 Part 2 Tail bracket mounting block (**item 2**) over the threads protruding from the rear of the bracket.
- Place the RG0036 rubber gasket (**item 3**) over the threads as this will sit between the mounting block and fender to protect the paint finish when mounted.
- Now place the bracket loosely into the rear fender so the 2 bolts just fitted protrude from the underside of the tail unit as shown in **picture 15 & 16**, ensure the rubber gasket completely protects the fender. *Ensure the wires are secure and neat from the rear of the bike before proceeding.*
- From inside of the fender, place two M6x12mm OD washers (**item 9**) over the exposed threads and secure using 2 x M6 Nyloc nuts (**item 10**). Do not fully tighten.
- Slide the S0365 lower mounting bracket spacer (**item 5**) between the bracket and lower hole of the fender stay.
- Now place the remaining M6 x 12OD washer (**item 9**) over the M6x25mm button head bolt (**item 7**) and thread through the lower tail bracket mounting hole and into the bike, ensuring the spacer is now sandwiched between the tail tidy and fender bracket.
- Place the M6x19mm OD washer (**item 8**) onto the exposed thread on the inside of the fender and secure with the remaining M6 Nyloc nut (**item 10**)
- Now align the tail tidy so it sits level and central then tighten the 3 nuts from the rear as shown in **Picture 16 & 17**. **DO NOT OVERTIGHTEN**. The Nyloc nuts will hold tight. The tail tidy should now be fully fitted as shown in **picture 18**.
- Connect the indicators to the connector block.
- If using R&G mini indicators, it may be necessary to use the bullet connector extensions (**item 20**) to reach the connector block.

For Honda CMX500 Models

- Connect the R&G bullet connectors using the colour chart below:

R&G REAR LIGHT	CON0025 CONNECTOR
YELLOW	GREEN
GREEN	PINK/BLUE
BLUE	YELLOW/GREEN

R&G

Unit 1, Shelley's Lane, East Worldham, Alton, Hampshire, GU34 3AQ

Tel: +44 (0)1420 89007 Fax: +44 (0)1420 87301 www.rg-racing.com Email: info@rg-racing.com



For Honda CMX1100 Models

- Connect the R&G bullet connectors using the colour chart below:

R&G REAR LIGHT	CON0086 CONNECTOR	CON0009
YELLOW	BLACK	
GREEN	BROWN	
BLUE		RED
EMPTY		BLACK

- **Test the brake light illuminates and functions correctly when the brake is applied.** If lights fail to illuminate or do not function as expected, then swap the bullet connectors around and re-test.
- Test both indicators and the licence plate light function correctly. If lights fail to illuminate, then swap the bullet connectors around and re-test.
- Re-fit the plastic panel removed earlier and fasteners by reversing the steps above.
- Ensure all wires are neat and will not be trapped by the seat or any moving components of the bike.
- Re-fit the licence plate (it may require drilling). A spanner may be required to fit the lower nut.
- Depending on local laws, attach enclosed reflector (**item 16**) in an appropriate location.
- Test the licence plate illuminator and all lights before riding.

IMPORTANT: FOR SAFETY, ENSURE THE LICENCE PLATE IS PLACED AS HIGH AS POSSIBLE ON THE TAIL TIDY (IT MAY REQUIRE DRILLING). IF FITTING A LICENCE PLATE OF 200MM OR LONGER (INCLUDING ANY SHROUD OR REFLECTOR ATTACHMENT) TO THE BRACKET, BEFORE RIDING, FULLY COMPRESS THE SUSPENSION TO ENSURE NO PART OF THE ASSEMBLY CAN CONTACT THE TYRE WHILE THE VEHICLE IS IN MOTION OR UNDER LOAD. IT IS YOUR RESPONSIBILITY TO CHECK FOR THIS POSSIBILITY AND TAKE AVOIDING ACTION. FAILURE TO CHECK THIS COULD RESULT IN SERIOUS INJURY OR DAMAGE TO THE MOTORCYCLE.

See more R&G products for your Motorcycle in the link below:

[R&G Racing | Cleaning/Lubrication - Gleam range for All Vehicles \(rg-racing.com\)](https://www.rg-racing.com)

ISSUE 1 14/04/2023 (DM)

CONSUMER NOTICE

The catalogue description and any exhibition of samples are only broad indications of the Products and R&G may make design changes which do not diminish their performance or visual appeal and supplying them in such state shall conform to the order. The Buyer acknowledges no representation or warranty (other than as to title) has been given or will apply to the Products other than those in R&G's order or confirmation and the Buyer confirms it has chosen the Products as being of merchantable quality and suitable for its particular purposes. Where R&G fits the Products or undertakes other services it shall exercise reasonable skill and care and rectify any fault free of charge unless the workmanship has been disturbed. The Buyer is responsible for ensuring that the warranty on the motorcycle is not affected by the fitting of the Products. On return of any defective Products R&G shall at its option either supply a replacement or refund the purchase money but shall not be liable if the Products have been modified or used or maintained otherwise than in accordance with R&G's or manufacturer's instructions and good engineering practice or if the defect arises from accident or neglect. Other than identified above and subject to R&G not limiting its liability for causing death and personal injury, it shall not be liable for indirect or consequential loss and otherwise its liability shall be limited to the amounts paid by the Buyer for the Products or the fitting or service concerned. These terms do not affect the Buyer's statutory rights.

R&G RACING RETURNS POLICY (NON-FAULTY GOODS)

Returns must be pre-authorized (if not pre-authorized the return will be rejected). Goods may only be returned direct to us if they were purchased direct from us (customer must prove if necessary). Otherwise to be returned to original vendor. Goods must be in re-sellable condition, in the opinion of R&G Racing. All returns are subject to a 25% restocking and handling fee (25% of the gross value exc. P&P – at the prevailing price at time of purchase). The customer must pay any and all carriage charges. No returns of discontinued products, unless within 14 days of purchase. This policy does not affect your statutory rights and does not refer to faulty goods.

R&G

Unit 1, Shelley's Lane, East Worldham, Alton, Hampshire, GU34 3AQ

Tel: +44 (0)1420 89007 Fax: +44 (0)1420 87301 www.rg-racing.com Email: info@rg-racing.com