

## Denali DM LED Driving Lights

TT-DM Instruction Rev: 01

### PLEASE READ BEFORE INSTALLING

TWISTED THROTTLE products should be installed by a qualified, experienced motorcycle technician. If you are unsure of your ability to properly install a product, please have the product installed by your local motorcycle dealer. TWISTED THROTTLE takes no responsibility for damages caused by improper installation.

All screws, bolts, and nuts, including all replacement hardware provided by TWISTED THROTTLE should be tightened to the torque specified in the OEM maintenance manual for your motorcycle. If no torque specifications are provided in the OEM maintenance manual, the following torques may be used:

M5.....	3.5 ft-lbs (5 Nm)
M6.....	7 ft-lbs (9.6 Nm)
M8.....	13 ft-lbs (18 Nm)

All screws, bolts, and nuts should be checked after driving the first 30 miles (50 km) to ensure that all are tightened to the proper torque.

Medium strength liquid thread-locker (i.e., "Loctite") should be used to secure all screws, bolts, and nuts.

Distributed by:	
Twisted Throttle LLC 570 Noose Neck Rd Exeter, RI 02822	phone: 401.284.4200 fax: 401.223.6955 www.twistedthrottle.com

**WARNING!** – Only use the included wiring harness to wire Denali lights. Even though the plug may be similar to other wiring, Denali lights have unique circuitry that can easily be damaged by using wiring other than the included harness.

**1**  
DM LED light Pod  
  
10° Optic Installed  
Qty.....2

**2**  
Hinge Link  
  
Qty.....2

**3**  
Socket Head Screw  
  
M3x12.....DIN 912  
Qty.....4

**4**  
40° Optic  
  
Qty.....2

**5**  
"U" Bracket Hinge  
  
M8 through hole  
Qty.....2

**6**  
Hex Head Screw  
  
M6x20.....DIN 933  
Qty.....2

**7**  
Spur Washer (M6)  
  
M6  
Qty.....4

**8**  
Lock Nut (M6)  
  
M6.....DIN 985  
Qty.....2

**9**  
Hex Head Screw  
  
M8x16.....DIN 933  
Qty.....2

**10**  
Lock Nut (M8)  
  
M8.....DIN 985  
Qty.....2

**11**  
Plastic Nut Cap  
  
Qty.....2

**12**  
Interlink  
  
Qty.....2

**13**  
Single Intensity  
Wiring Harness  
  
5 Amp Fuse  
Qty.....1

**14**  
Posi-tap Connector  
  
Qty.....1

**15**  
Allen Key  
  
2.5mm  
Qty.....1

**16**  
Zip Tie  
  
Black  
Qty.....4

# Mounting Instructions

Mounting illustration is for assembly reference only. Actual components may vary from components illustrated.

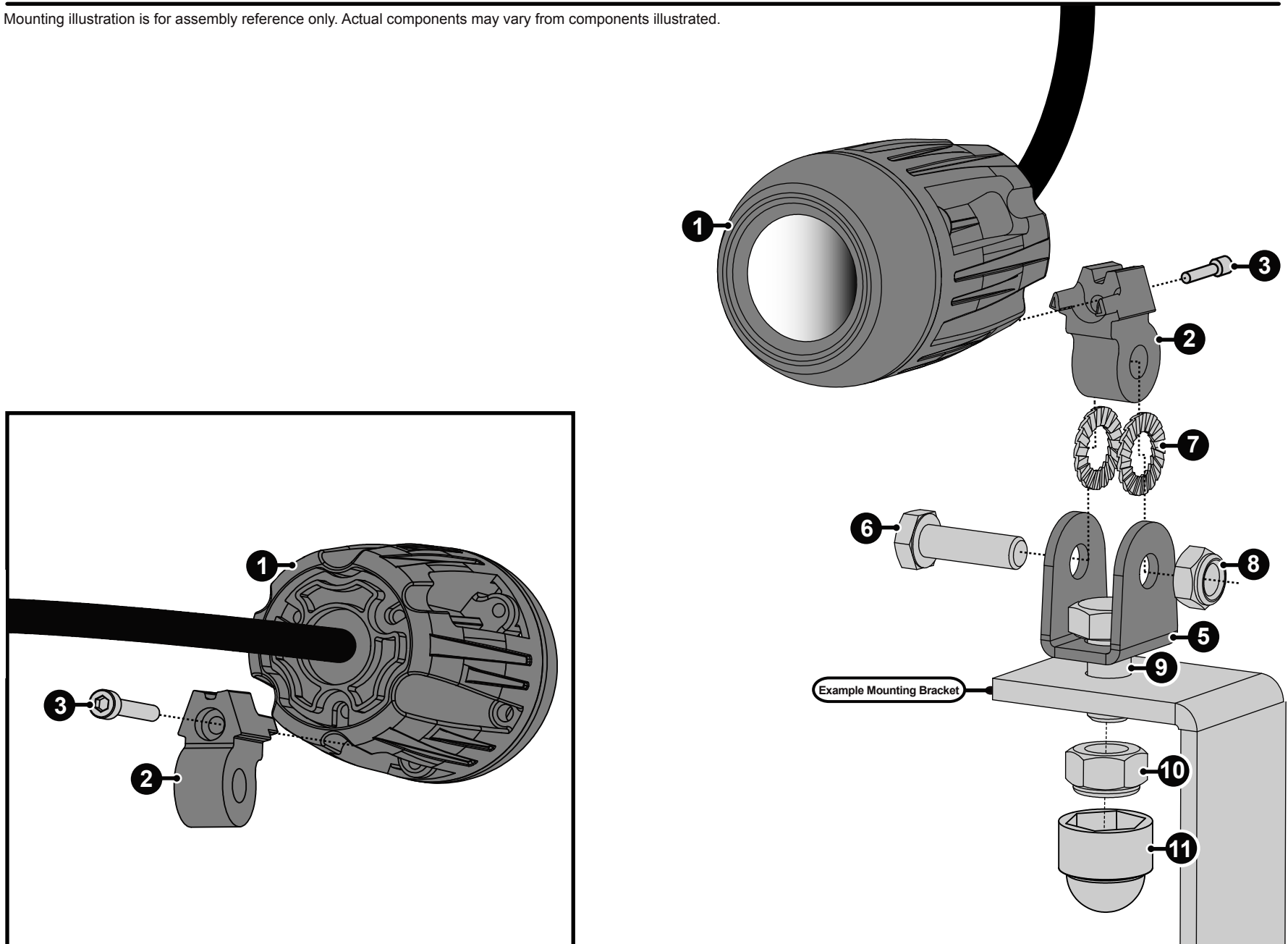

# Wiring Instructions

## Option 1 (Lights controlled by Denali on / off switch):

- (1) Attach the positive and negative ring terminals to the battery.
- (2) Identify the **white** wire (switched power) . Use one posi-tap connector to tap the white wire into any switched 12 volt power source. For example, your motorcycles running light wire or dash light wire are a switched 12 volt power source.
- (3) Connect the DM Lights and mount the switch. Check to make sure they are functioning properly. Make sure all wires and switch are properly routed from the battery to the lights avoiding hot surfaces, sharp objects, and moving parts.

## Option 2 (Lights controlled by your motorcycles high beam switch):

- (1) Attach the positive and negative ring terminals to the battery.
- (2) Identify the **white** wire (switched power) . Use one posi-tap connector to tap the white wire into the motorcycles high beam headlight wire. In this wiring configuration, your Denali lights will be operated through your bikes high beam switch. To turn the lights off entirely simply toggle the switch included with the Denali lights.
- (3) Connect the DM Lights and mount the switch. Check to make sure they are functioning properly. Make sure all wires and switch are properly routed from the battery to the lights avoiding hot surfaces, sharp objects, and moving parts.

Note: Universal and bike specific mounting kits are available at [twistedthrottle.com](http://twistedthrottle.com). Additional wiring options are possible. Visit [twistedthrottle.com/denali2](http://twistedthrottle.com/denali2) to view an installation tutorial.

## Wiring Diagram

Note: This drawing is not to scale and is intended for illustrative purposes only.

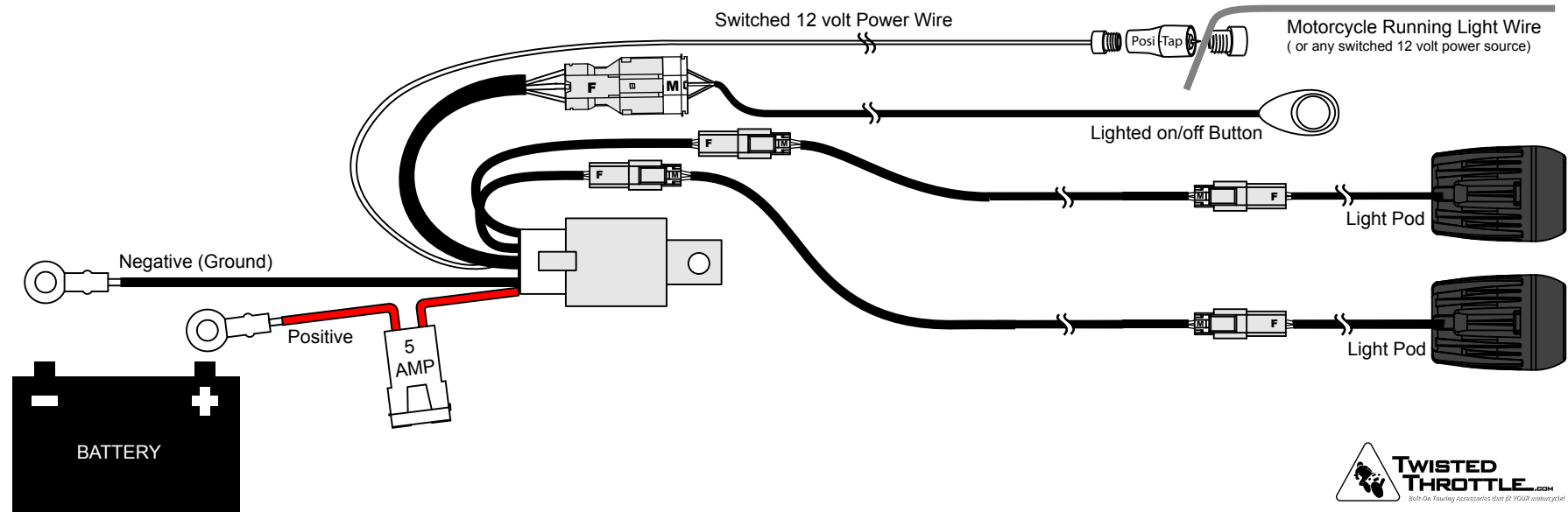

**WARNING!** – If mounting the lights to the front fender, forks, or fairing, turn the handlebars fully left and right and fully compress & uncompress the suspension to ensure the wires will not bind and have enough slack for your motorcycle to operate properly.